

Operating and Installation Instructions

Micro Diaphragm Gas Pumps

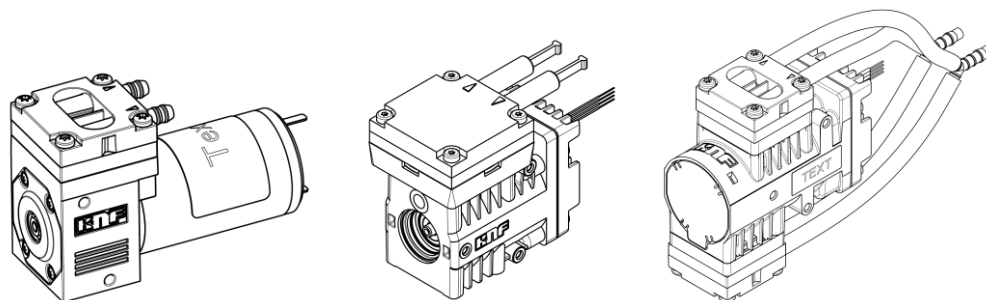

Type range:

NMP 830 KPDC	NMP 830 KPDC-BI	NMP 830.1.2 KPDC-BI
NMP 830 KVDC	NMP 830 KVDC-BI	NMP 830.3 KPDC-BI
NMP 830 KTDC	NMP 830 KTDC-BI	NMP 850.1.2 KPDC-BI
NMP 830 KVE	NMP 830 KTE	NMP 850.3 KPDC-BI
NMP 850 KPDC	NMP 850 KPDC-BI	
NMP 850 KTDC	NMP 850 KTDC-BI	

You have selected a high-quality KNF product; the following tips will help you operate it safely, and reliably over a long period of time. Carefully study the Operating and Installation Instructions before using the pumps and observe at all times the relevant instructions to avoid dangerous situations. The manual was produced for the serial pumps stated above. With customer-specified projects (pump types starting with "PJM" or "PMM") there could be differences in detail. For customer-specified projects please therefore take into account any agreed technical specifications, as well as these instructions.

	Contents	Page
	1. About this document.....	2
	2. Use	3
	3. Safety	4
	4. Technical Data.....	6
	5. Design and function.....	10
	6. Installation and connection	11
	7. Operation.....	16
	8. Servicing.....	17
	9. Troubleshooting.....	21
	10. Returns	23

KNF Micro AG
 Zelglimatte 1b
 CH-6260 Reiden
 Switzerland
 Phone 0041(0)62 787 88 88
 E-mail: info.micro@knf.com
www.knf.com

1. About this document

1.1. Using the Operating and Installation Instructions

The Operating and Installation Instructions are part of the pump.

→ Pass on the Operating and Installation Instructions to the next owner.

Project pumps Customer-specific project pumps (pump models which begin with "PJ", "PM", "PJM" or "PMM") may differ from the Operating and Installation Instructions.

→ For project pumps, also observe the agreed upon specifications.

1.2. Symbols and markings

Warning



A danger warning is located here.

Possible consequences of a failure to observe the warning are specified here. The signal word, e.g.

WARNING Warning, indicates the danger level.

→ Measures for avoiding the danger and its consequences are specified here.

Danger levels

Signal word	Meaning	Consequences if not observed
DANGER	warns of immediate danger	Death or serious injuries and/or serious damage are the consequence.
WARNING	warns of possible danger	Death or serious injuries and/or serious damage are possible.
CAUTION	warns of a possibly dangerous situation	Minor injuries or damage are possible.

Tab. 1

Other information and symbols

→ An activity to be carried out (a step) is specified here.

1. The first step of an activity to be carried out is specified here. Additional, consecutively numbered steps follow.

i This symbol refers to important information.

2. Use

2.1. Proper use

The pumps are exclusively intended for transferring gases.

Owner's responsibility

Operating parameters and conditions

Only install and operate the pumps under the operating parameters and conditions described in Chapter 4, Technical data.

Only complete pumps may be taken into service.

Make sure that the installation location is dry, and the pump is protected against rain, splash, hose, and drip water.

Requirements for transferred medium

Before using a medium, check whether the medium can be transferred danger-free in the specific application case.

Before using a medium, check the compatibility of the materials of the pump head, pump housing, diaphragms, and valves with the medium.

Only transfer gases which remain stable under the pressures and temperatures occurring in the pump.

2.2. Improper use

The pumps may not be operated in an explosive atmosphere.

The pumps are not suitable for transferring dusts.

The pumps are not suitable for transferring vapors and liquids.

The pumps must not be used to create vacuum and overpressure simultaneously.

An overpressure must not be applied to the suction side of the pump.

3. Safety

i Note the safety precautions in Chapters 6. *Installation and connection*, and 7. *Operation*.

The pumps are built according to the generally recognized rules of technology and in accordance with the occupational safety and accident prevention regulations. Nevertheless, dangers can result during their use which lead to injuries to the user or others, or to damage to the pump or other property.

Only use the pumps when they are in a good technical and proper working order, in accordance with their intended use, observing the safety advice within the Operating and Installation Instructions, at all times.

Personnel	<p>Make sure that only trained and instructed personnel or specially trained personnel work on the pumps. This especially applies to assembly, connection and servicing work.</p> <p>Make sure that the personnel has read and understood the Operating and Installation Instructions, and in particular the "Safety" chapter.</p>
Working in a safety-conscious manner	Observe the accident prevention and safety regulations when performing any work on the pump and during operation.
Handling dangerous media	When transferring dangerous media, observe the safety regulations when handling these media.
Handling combustible media	<p>Be aware that the pumps are not designed to be explosion-proof.</p> <p>Make sure the temperature of the medium is always sufficiently below the ignition temperature of the medium, to avoid ignition or explosion. This also applies for unusual operational situations.</p> <p>Note that the temperature of the medium increases when the pump compresses the medium.</p> <p>Hence, make sure the temperature of the medium is sufficiently below the ignition temperature of the medium, even when it is compressed to the maximum permissible operating pressure of the pump.</p> <p>If necessary, consider any external sources of energy, such as radiation, that may add heat to the medium.</p> <p>In case of doubt, consult the KNF customer service.</p>
Environmental protection	<p>Store the pump and all accessories in accordance with the environmental provisions. Observe national and international regulations. This applies in particular to parts that are contaminated with toxic substances.</p> <p>If you no longer need your packaging materials (e.g. for return shipment or other transport of the device), dispose of them in an environmentally friendly manner.</p> <p>Old devices must not be disposed of with household waste. Proper disposal and recycling helps to protect natural resources and the environment. The end user is responsible for disposing of old devices according to national and international regulations. Alter-</p>

	natively, KNF products (old devices) may also be returned to KNF for a fee (see chapter Returns).
EC Directives / Standards	<p>For the purposes of the Machinery Directive 2006/42/EC, pumps are “partly completed machinery,” and are therefore to be regarded as not ready for use. Partly completed machinery may not be commissioned until such time as it has been determined that the machine in which the partly completed machinery is to be assembled is in conformity with the provisions of the Machinery Directive 2006/42/EC. The following essential requirements of Annex I of Directive 2006/42/EC (general principles) are applied and observed:</p> <ul style="list-style-type: none"> - General Principles No. 1 - No. 1.1.2. / 1.1.3. / 1.3.1. / 1.3.3. / 1.3.4. / 1.4.1. / 1.5.1.* / 1.5.2.* / 1.5.8. / 1.5.9. / 1.7.4. / 1.7.4.1. / 1.7.4.3. (* only for pump type NMP 830 K_E) <p>As these partly completed machinery are OEM-models the power supplies and the equipment for disconnecting and switching-off the partly completed machinery respectively have to be considered when mounting as well as over-current and overload protective gear.</p> <p>In addition a protection against mechanical parts in motion and hot parts, if existing, has to be provided when mounting.</p> <p>The pumps conform to the Directive 2011/65/EU (RoHS2).</p>
Customer service and repairs	Only have repairs to the pumps carried out by the KNF Customer Service responsible.

4. Technical Data

Pump materials

NMP 830 KPDC, NMP 830 KPDC-BI

Assembly	Material
Head plate; intermediate plate	PPS
Housing	PA
Valve plate	EPDM
O-ring	EPDM
Diaphragm	EPDM

Tab. 2

NMP 850 KPDC, NMP 850 KPDC-BI

Assembly	Material
Head plate; intermediate plate	PPS
Housing	PA
Valve plate	EPDM
Diaphragm	EPDM

Tab. 3

NMP 830 KVDC, NMP 830 KVDC-BI

NMP 830 KVE

Assembly	Material
Head plate; intermediate plate	PPS
Housing	PA
Valve plate	FPM
O-ring	FPM
Diaphragm	FPM

Tab. 4

NMP 830 KTDC, NMP 830 KTDC-BI

NMP 850 KTDC, NMP 850 KTDC-BI

NMP 850 KTE

Assembly	Material
Head plate; intermediate plate	PPS
Housing	PA-GF33
Valve plate	FFPM
O-ring	FPM
Diaphragm	PTFE coated

Tab. 5

NMP830.1.2 KPDC-BI, NMP830.3 KPDC-BI

Assembly	Material
Head plate; intermediate plate	PPS
Housing	ALUMINIUM
Valve plate	EPDM
O-ring	EPDM
Diaphragm	EPDM

Tab. 6

NMP850.1.2 KPDC-B, NMP850.3 KPDC-BI

Assembly	Material
Head plate; intermediate plate	PPS
Housing	ALUMINIUM
Valve plate	EPDM
Diaphragm	EPDM

Tab. 7

Pneumatic values

Pump type	Delivery rate at atm. pressure [l/min]*	Max. permissible operating pressure [bar g]	Ultimate vacuum [mbar abs.]
NMP 830 KNE	1.8	1.0	250
NMP 830 KVE			310
NMP 830 KTE	1.6		250
NMP 830 KPDC	3.1		250
NMP 830 KVDC	2.7		350
NMP 830 KTDC	2.6		250
NMP 830 KPDC-BI	2.5	1.4	250
NMP 830 KVDC-BI	2.2		300
NMP 830 KTDC-BI	2.1	1.2	230
NMP 830.1.2 KPDC-BI	5.6	1.5	55
NMP 830.3 KPDC-BI	2.9	-	230
NMP 850 KPDC	4.5	1.5	300
NMP 850 KTDC	3.9		230
NMP 850 KPDC-BI	4.2		300
NMP 850 KTDC-BI	4.0		230
NMP 850.1.2 KPDC-BI	8.5		60
NMP 850.3 KPDC-BI	4.2	-	

Tab. 8

* Liters in standard state (1,013 mbar)

Electrical data

Parameter	Value
Electrical data	See type plate

Tab. 9

Dimensions

Pump type	Dimensions [L x W x H]
NMP 830 E	approx. 98 x 56 x 66
NMP 830 DC	approx. 76 x 30,5 x 51
NMP 830 DC-BI	approx. 58,3 x 33,4 x 56,2
NMP 830.1.2 DC-BI	ca. 141 x 33,4 x 77,3
NMP 830.3 DC-BI	ca. 96 x 33,4 x 77,3
NMP 850 DC	approx. 80.5 x 38 x 54
NMP 850 DC-BI	approx. 58,3 x 38 x 59,9
NMP 850.1.2 DC-BI	ca. 149 x 38 x 83,6
NMP 850.3 DC-BI	ca. 102 x 38 x 83,6

Tab. 10

Weight

Pump type	Weight [kg]
NMP 830 E	approx. 0.590
NMP 830 DC	approx. 0.195
NMP 830 DC-BI	approx. 0.161
NMP 830.1.2 DC-BI	approx. 0.253
NMP 830.3 DC-BI	approx. 0.251
NMP 850 DC	approx. 0.210
NMP 850 DC-BI	approx. 0.195
NMP 850.1.2 DC-BI	approx. 0.298
NMP 850.3 DC-BI	approx. 0.296

Tab. 11

Other parameters

Parameter	Values
Pneumatic connections NMP 830 NMP 830.1.2 NMP 830.3 NMP 850.1.2	For tube ID 4 mm
Pneumatic connections NMP 850 NMP 850.3	For tube ID 5 mm
Permissible ambient temperature	+ 5 °C to + 40 °C
Permissible media temperature	+ 5 °C to + 40 °C
Maximum permissible ambient relative humidity	80 % for temperatures up to 31 °C, decreasing linearly to 50 % at 40 °C
Max. altitude of site [m above sea level]	2000

Tab. 12

5. Design and function

Design

- 1 Motor
- 2 Inlet
- 3 Outlet
- 4 Pump head

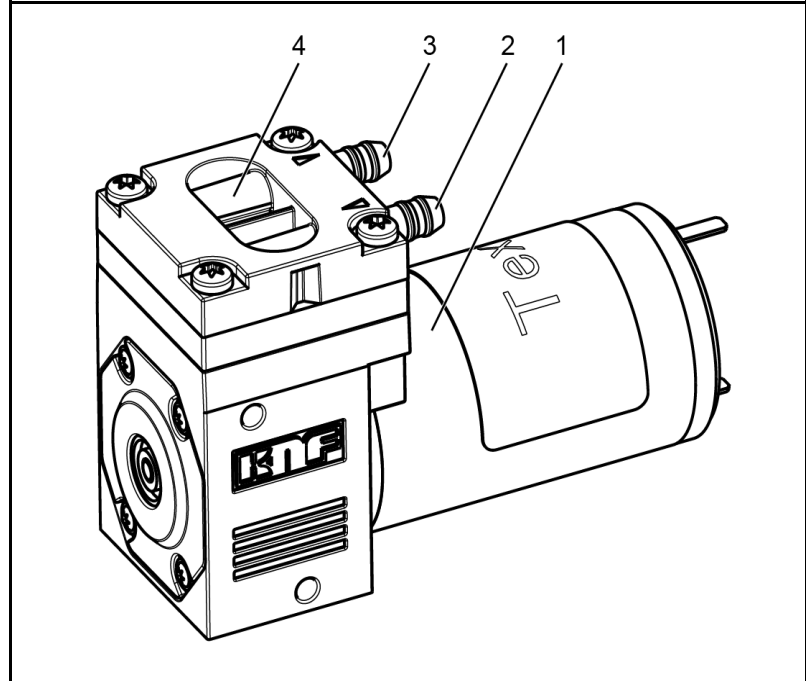

Fig. 1: Diaphragm pump NMP 830__DC

Function

- 1 Outlet valve
- 2 Inlet valve
- 3 Transfer chamber
- 4 Diaphragm
- 5 Eccentric
- 6 Connecting rod
- 7 Pump drive

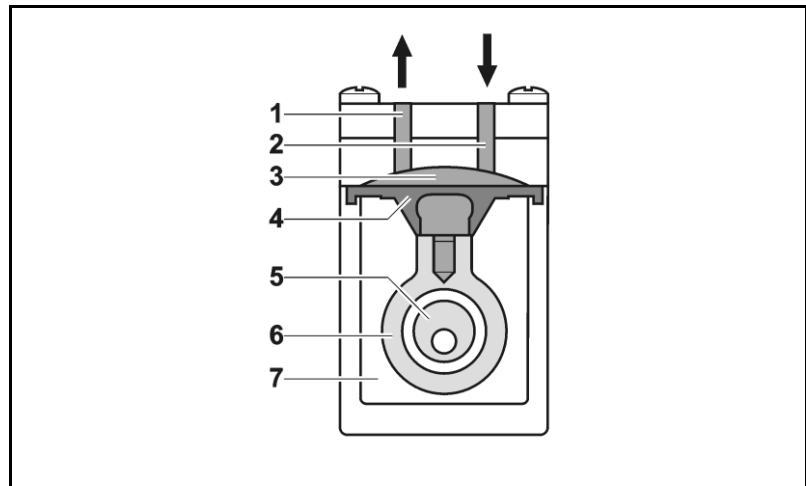

Fig. 2: Pump head

The pumps transfer, compress and evacuate gases.

The elastic diaphragm (4) is moved up and down by the eccentric (5) and the connecting rod (6). In the downward stroke it aspirates the gas to be transferred via the inlet valve (2). In the upward stroke, the diaphragm presses the medium out of the pump head via the outlet valve (1). The transfer chamber (3) is hermetically separated from the pump drive (7) by the diaphragm.

6. Installation and connection

Only install and operate the pumps under the operating parameters and conditions described in Chapter 4, Technical data.

Observe the safety precautions (see Chapter 3).

6.1. Installation of the pump

- Before installation, store the pump at the installation location to bring it up to ambient temperature.
- See the data sheet for the mounting dimensions.
- Make sure that the installation location is dry and the pump is protected against rain, splash, hose and drip water.
- Install the pump at the highest point in the system to prevent condensate from collecting in the pump head.
- Choose a safe location (flat surface) for the pump.
- Protect the pump from dust.
- Protect the pump from vibrations and jolts.

Touch and foreign object protection

For pumps with alternating current motors:



WARNING

Danger of injury during operation

- Take protective measures against touching parts which are energised (live), such as electrical connections or windings.
- Take protective measures against touching moving parts (e.g. fan).

Danger of damaging the pump during operation

- Take protective measures to ensure that no foreign objects can get into the pump or penetrate the motor (see protection class).

6.2. Electrical connection

For pumps with alternating current motors:



DANGER

Risk of electric shock, danger of death

- Pump should only be connected by a specialist.
- Only connect the pump when the power supply is turned off.

For pumps with alternating current motors:

- Only have the pump connected by an authorized specialist.
- Only have the pump connected when the power supply is disconnected.
- All electrical connection work must adhere to the pertinent guidelines, regulations and technical standards.

Connecting pump

1. Compare the supply data with the data on the motor-plate. For operating current see type plate.

i The voltage must not vary by more than + 10% and - 10% from that shown on the type-plate.

2. Connect the earth (ground) wire to the motor (not necessary on dc motors up to 24V).

3. Connect the positive and negative pole.

i Always check polarity of cables.

For DC motors:

red motor lead: +

black motor lead: -

In the case of brushless DC motors:

incorrect polarity may cause damage to the electronics.

EMC-compatible Installation brushed DC-Motor

The Tests:

- Magnetic field with energy-technical frequency
- Electromagnetic HF field, amplitude-modulated
- Electromagnetic HF field, pulse-modulated
- Discharging of static electricity
- High frequency, asymmetric
- Fast transients

were not carried out, cause the products do not contain electronic modules, which can be affected by these tests.

The Surge-test can only be passed with additional means, or is not mandatory, if:

From EN61000-6-1 technical norm for EMC protection, part 1,10 test demands for EMC protection, table 3, EMC protection, D.C.- power in- and outputs. Remark 3: (quotation) Not to be used with input connections which are foreseen for a connection with a battery or a rechargeable battery which has to be removed or disconnected from the device for the recharge.

Devices with a D.C. power input which are foreseen to be operated with an A.C. / D.C. converter have to be tested at an A.C. power input of an A.C. / D.C. converter fixed by the manufacturer. In case the converter was not fixed they have to be tested at an A.C. power input of a typical (usual) A.C. / D.C. converter.

The test is applicable for D C power inputs which are foreseen for a permanent connection to cables which are longer than 10 m.

EMC-compatible Installation
brushless DC-Motor

In order to remove the electrical interference according to EN 55014-1:1993 + A1:1997 all pumps with brushless DC motor (DC-BI) must be equipped with an additional electronic circuit. This electronic circuit has to be installed as close to the motor as possible.

The supplemental circuit must be structured according to the following electrical diagram and the components defined therein in order to achieve the required level of suppression

C1: Capacitor
≥ 470 µF

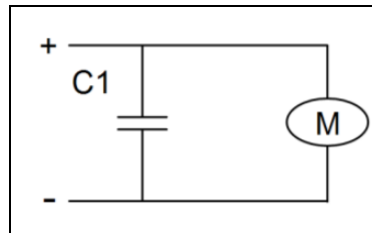

Fig. 3: Electrical diagram of the supplemental circuit

6.3. Pneumatic connection

Connected
components

→ Only connect components to the pump which are designed for the pneumatic data of the pump (see Chapter 4, Technical data).

Pump exhaust

→ If the pump is used as a vacuum pump, safely discharge the pump exhaust at the pump's pneumatic outlet.

Connecting pump

i A marking on the pump head shows the direction of flow.

1. Remove the protective plugs from the hose connectors.
2. Connect the suction line and pressure line.
3. Lay the suction and pressure line at a downward angle to prevent condensate from running into the pump.

6.4. Fixation

Fixation (for NMP830K_DC and NMP850K_DC)

The pump offers two mounting points, which allow an easy fixation of the pump with either 2x Delta PT35 screws on the side or 4x DIN 912 M3 screws on the bottom with max. 0.5 Nm torque.

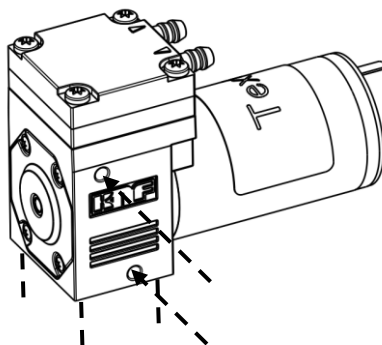

Fixation (for NMP830K_DC-BI and NMP850K_DC-BI)

The pump offers an easy fixation with 4x Delta PT30 screws on the bottom or 3x Delta PT30 screws on the sides.

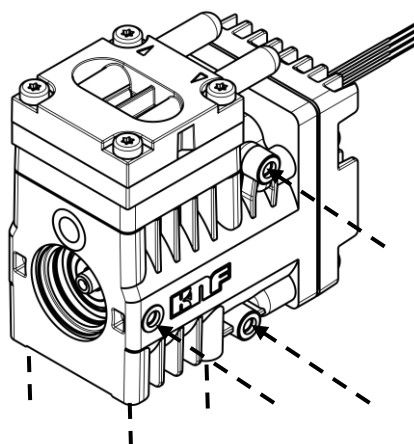

Fixation (for NMP830.X / NMP850.X)

The pump offers an easy fixation with 3x DIN7500C M3 screws on the sides (screw-in depth 5mm).

Max. torque 1.1Nm

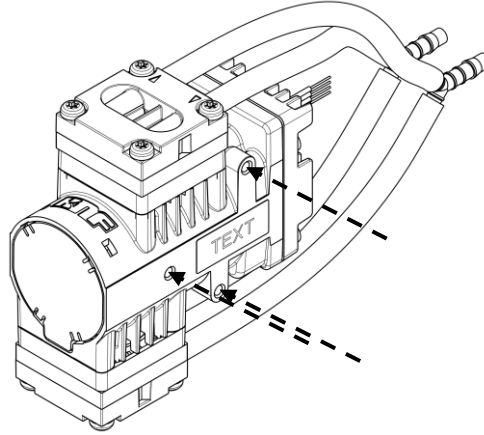

7. Operation

Only operate the pumps under the operating parameters and conditions described in Chapter 4, Technical data.

Make sure the pumps are used properly (see Chapter 2.1).

Make sure the pumps are not used improperly (see Chapter 2.2).

Observe the safety precautions (see Chapter 3).



WARNING

Hazard of the pump head bursting due to excessive pressure increase

- Do not exceed max. permissible operating pressure (see Chapter 4, Technical data).
- Monitor pressure during operation.
- If the pressure exceeds the maximum permissible operating pressure, immediately switch off pump and eliminate fault (see Chapter 8. Troubleshooting).
- Only throttle or regulate the air or gas quantity in the suction line to prevent the maximum permissible operating pressure from being exceeded.
- If the air or gas quantity in the pressure line is throttled or regulated, make sure that the maximum permissible operating pressure is not exceeded.

i Excessive pressure (with all of the related hazards) can be prevented by placing a bypass line with a pressure-relief valve between the pressure and suction sides of the pump. For further information, contact our technical adviser (see front page for telephone number).

Pump standstill → With the pump at a standstill, open pressure vacuum and suction lines to normal atmospheric pressure.

Switching pump on **i** The pump may not start up against pressure or vacuum during switch-on. This also applies in operation following a brief power failure.

→ Make sure that normal atmospheric pressure is present in the lines during switch-on.

Inspection → Regularly inspect the pump for external damage or leaks. Diaphragm and valve plate(s) are the only parts subject to wear. Wear is usually indicated by a drastic reduction in the pneumatic performance. When replacing parts proceed as described in Chapter 8.

8. Servicing

Before working on the pump, isolate the power supply securely, then check that the lines are not live.

Always change valve plate(s), diaphragm, and O-rings (if existing) at the same time.

8.1. NMP 830

Parts required

Type range	Part	Order-No.
NMP 830 KP_	1 Diaphragm 2 Valve plates 2 O-Rings	045742 125971 056651
NMP 830 KV_	1 Diaphragm 2 Valve plates 2 O-Rings	051574 126108 023545
NMP 830 KT_	1 Diaphragm 2 Valve plates 2 O-Rings	073735 125970 023545
NMP 830.1.2 KP_ NMP 830.3 KP_	2 Diaphragm 4 Valve plates 4 O-Rings	045742 125971 056651

Tab. 13: Parts

Tools required

Tool
Torx screwdriver, Torx 10 IP
Pencil

Tab. 14: Tools

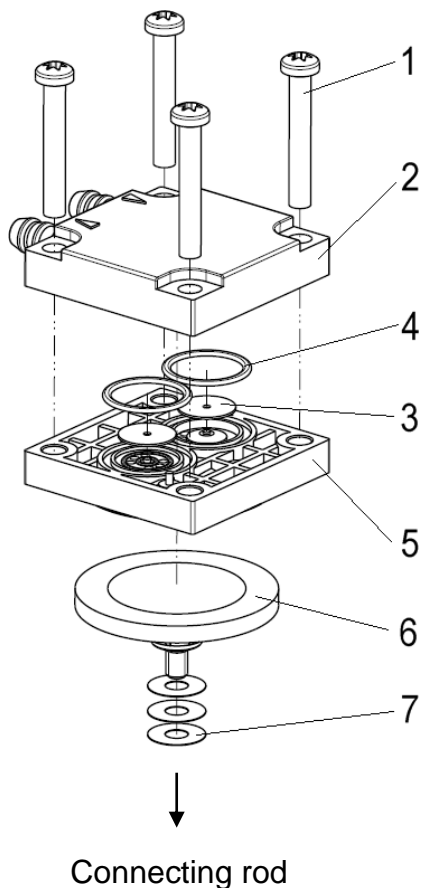

Fig. 4: Pump head NMP 830 K

Specification

- 1 Screw
- 2 Head plate
- 3 Valve plate
- 4 O-ring
- 5 Intermediate plate
- 6 Diaphragm
- 7 Spacer

See fig. 4.

1. Mark the position of head parts relative to each other by a drawing line with a pencil. This helps to avoid incorrect assembly later.
2. Undo the four screws (1) in the head.
3. Lift the head plate (2) and the intermediate plate (5) complete with valve plates (3) and O-rings (4) off the housing.
4. Hold the pump with one hand, so that the diaphragm is pointing downwards. Lift the diaphragm (6) by the opposing side edges, grasp it and unscrew it in the counter-clockwise direction.
5. Take the diaphragm spacers (7) off the threaded portion of the diaphragm and put them on the threaded portion of the new diaphragm.
6. Move the connecting rod to the upper point.
7. Screw the new diaphragm (6) with spacers (7) clockwise onto the connection rod and tighten hand-tight.
8. Place the intermediate plate (5) on the housing, in the position indicated by the drawing line.
9. Exchange both valve plates (3) and both O-rings (4). The valve plates for pressure and suction sides are identical, as are upper and lower sides of the plates.
10. Place the head plate (2) on the intermediate plate (5), in the position indicated by the drawing line; gently tighten the four screws (1) evenly and diagonally (if a torque screwdriver is available: torque about 0.30 Nm).
11. Let the pump run.

8.2. NMP 850

Parts required

Type range	Parts	Order-No.
NMP 850 KP_	1 Diaphragm 1 Valve plate	314717 059785
NMP 850.1.2 KP_ NMP 850.3 KP_	2 Diaphragms 2 Valve plates	314717 059785
NMP 850 KT_	1 Diaphragm 1 Valve plate	059784 059786

Tab. 15: Parts

Tools required

Tools
Torx screwdriver, Torx 10 IP
Pencil

Tab. 16: Tools

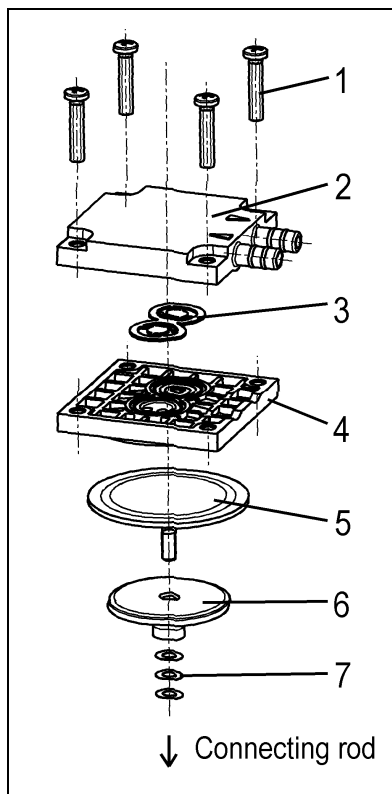

Fig. 5: Pump head NMP 850 K_

Specification

- 1 Screw
- 2 Head plate
- 3 Valve plate (one piece)
- 4 Intermediate plate
- 5 Diaphragm
- 6 Connecting rod disc
- 7 Spacer

See fig. 5.

For pump NMP 850.1.2 KPDCB:

To avoid opening the pneumatic connection between the pump heads service the pump as described below with the following addition: Make steps 1 to 3 and 11 for both pump heads together.

1. Mark the position of head parts relative to each other by a drawing line with a pencil. This helps avoid incorrect assembly later.
2. Undo the four screws (1) in the head.
3. Lift the head plate (2) and the intermediate plate (4) off the housing.
4. Hold the pump with one hand, so that the diaphragm is pointing downwards. Lift the diaphragm (5) by the opposing side edges, grasp it and unscrew it in the counter-clockwise direction.
5. Remove connection rod disc (6) and diaphragm spacers (7) from the threaded pin of the diaphragm.
6. Push the connection rod disc (6) and the diaphragm spacers (7) in this order onto the threaded pin of the new diaphragm.
7. Move the connecting rod to the upper point.

8. Screw the new diaphragm (5) with connection rod disc (6) and spacers (7) clockwise onto the connection rod and tighten hand-tight.
9. Place the intermediate plate (4) on housing, in the position indicated by the drawing line.
10. Place the new valve plate (3) on the intermediate plate (4).
11. Place the head plate (2) on the intermediate plate (4), in the position indicated by the drawing line; gently tighten the four screws (1), evenly and diagonally (if a torque screwdriver is available: torque about 0.30 Nm).
12. Let the pump run.

9. Troubleshooting

- ➔ Disconnect the pump power supply before working on the pump.
- ➔ Make sure the pump is deenergized and secure.

Check the pump (see Tab. 17 and 18).

Pump does not transfer	
Cause	Fault remedy
Connections or lines blocked.	<ul style="list-style-type: none"> ➔ Check connections and lines. ➔ Remove blockage.
External valve is closed or filter is clogged.	➔ Check external valves and filters.
Condensate has collected in pump head.	➔ Install pump at highest point in system.
Diaphragm or valve plates are worn.	➔ Replace pump.

Tab. 17

Flow rate, pressure or vacuum too low	
The pump does not achieve the output specified in the Technical data or the data sheet.	
Cause	Fault remedy
Condensate has collected in pump head.	➔ Install pump at highest point in system.
There is gauge pressure on pressure side and at the same time vacuum or a pressure above atmospheric pressure on suction side.	➔ Change the pressure conditions.
Pneumatic lines or connection parts have an insufficient cross section.	<ul style="list-style-type: none"> ➔ Disconnect pump from system to determine output values. ➔ Eliminate throttling (e.g. valve) if necessary. ➔ Use lines or connection parts with larger cross section if necessary.
Leaks occur on connections, lines or pump head.	➔ Eliminate leaks.
Connections or lines completely or partially jammed.	<ul style="list-style-type: none"> ➔ Check connections and lines. ➔ Remove the jamming parts and particles.
Head parts are soiled.	➔ Clean head components.
Diaphragm or valve plates are worn.	➔ Change diaphragm or valve plates (see Chapter 8 Servicing).

Tab. 18

Fault cannot be rectified

If you are unable to determine any of the specified causes, send the pump to KNF Customer Service (see last page for the address).

1. Flush the pump to free the pump head of dangerous or aggressive gases.
2. Remove the pump
3. Clean the pump
4. Send the pump, together with completed Health and Safety Clearance and Decontamination Form (Chapter 10), to KNF stating the nature of the transferred medium.

10. Returns

Preparing for return

1. Flush the pump with air for a few minutes (if necessary for safety reasons: with inert gas) to free the pump head of dangerous or aggressive gases (see Chapter Flushing the pump).

i Please contact your KNF sales partner if the pump cannot be flushed due to damages

2. Remove the pump.
3. Clean the pump (see the Chapter Cleaning the pump).
4. Send the pump together with completed Health and Safety Clearance and Decontamination Form to KNF, stating the nature of the transferred medium.
5. Package the device securely to prevent further damage to the product. If necessary, request an original packaging at a charge.

Returns

KNF shall undertake to repair the pump only under the condition that the customer presents a certificate regarding the medium that is pumped and the cleaning of the pump. Please follow the instructions at knf.com/repairs.

Contact your KNF sales partner directly if you require additional support for your return service.

KNF worldwide

Find our local KNF partner on: www.knf.com



