

# DIAPHRAGM PRESSURE CONTROL VALVE

## FDV 30/31, 1.30/1.31, 300/301, 1.300/1.301

E 760



### Concept

The KNF diaphragm pressure valve can be used to keep the system pressure constant, as a pressure relief valve to reduce pressure peaks or in order to prevent the liquid from being sucked directly through the pump. This accessory can be used in combination with a KNF diaphragm pump or as an individual product.

The FDV pressure valves are suitable for use with liquids and gases. The required pressure can be set by using a spindle/spring combination. This presses down on a diaphragm which is in contact with the liquid or gas.

Different material combinations of the wetted parts allow the correct solution for every application.

#### Note:

Pressure control valves are not absolutely tight shut off valves. They need to be installed on the pressure side of the pump.

### Features

#### Compact and lightweight

Intricate design has resulted in a valve that is both small in size and light in weight.

#### Use with liquid and gaseous media

The careful design of the valve makes them equally suitable for use with both liquids or gases.

#### Extreme chemical resistance

The use of chemically resistant materials such as PVDF, PTFE, FPM or other material combinations in the liquid contacting parts facilitates the pumping of almost all neutral or corrosive media.

#### Durable and maintenance free

The carefully considered design of these pressure control valves ensures safe operation and a long life even under the most severe conditions.

### Areas of use

#### Pressure control function

The pressure control valve serves to produce a constant back pressure. It can be used for a more accurate control of flow against a fluctuating back pressure, metering into a vacuum and from a pressurised system.

#### Bypass function

The bypass valve restricts the build up of excessive pressure on the outlet side of the pump. If an excessive back pressure occurs, the bypass valve opens and the liquid is re-circulated. The liquid re-circulates thus protecting the pump until such time as the restriction is removed.

#### Anti-injection function

When pumping into a tube which contains a fast flowing liquid, venturi action can occur. This has a negative effect on the dosing accuracy. With the built-in diaphragm pressure control valve the venturi action can be eliminated. Furthermore the pressure control valve function assists the dosing accuracy even though the pipework pressure may vary.

## Performance Data

Type	Min. pressure (bar g)	Max. pressure (bar g)	Max. flow rate with liquid (l/min)	Max. flow rate with gas (NI/min)
FDV 30/31	0.2	2.5	3	150
FDV 1.30/1.31	2.0	6.5	3	150
FDV 300/301	0.8	2.5	12	300
FDV 1.300/1.301	2.0	6.5	12	300

# Models

## Assembly and Function



### Models

#### General notes

This Data Sheet contains information about the product range FDV 30/31 and FDV 300/301. In the following, all components are explained in detail.

#### Performance charts

The performance charts illustrate the working pressure  $p_A$  (bar) and the flow rate  $Q$  (l/min).

The working pressure indicates the adjusted opening pressure of the valve plus the pressure which is created by the liquid flow.

The illustrated performance charts are based on water as a liquid (l/min) and air as a gas (NI/min), both being at 20°C. Small deviations from these charts can occur depending on the materials being used.

#### Basic models

- FDV -. Pressure valve for a maximum working pressure of 2.5 bar g
- FDV 1. Pressure valve for a maximum working pressure of 6.5 bar g

### 1 Head types

#### Shaft spindle / locknut

The spindle allows a precise adjustment of the working pressure and is then fixed into place by the locknut. This prevents any accidental movement.

#### Turning knob

This knob allows a quick adjustment of the opening pressure without the use of tools.

### 2 Materials (wetted parts)

KNF FLODOS offers a wide range of different materials for those areas which come in contact with the media thus allowing the possibility of pumping most gaseous and liquid media.

### Assembly and function

The design of the FDV pressure control valve is based on the technology of diaphragm valves. The essential components are the upper body **2**, the lower body **1**, the spindle system (resp. the turning knob) and the diaphragm **3**.

The required opening pressure is readily adjusted by the tension of the pressure spring **7**. The spring tension applies a force to the diaphragm **3** which is transferred to the fluid system. By turning the spindle **9** (resp. the turning knob) clockwise the opening pressure increases under constant flow rate; turning counter-clockwise decreases the opening pressure. With the shaft spindle/locknut head, the spindle **9** can be fixed with the locknut **10**, and consequently any unintentional adjustment is prevented.

In the static position the diaphragm **3** is pressed over the connection channel, separating the inlet from the outlet port. If the pressure in the fluid or gas system exceeds the set spring pressure, the diaphragm **3** will be pushed up. This opens up the connection channel allowing the liquid/gas to flow until such time as the pressure in the system falls below the spring pressure.

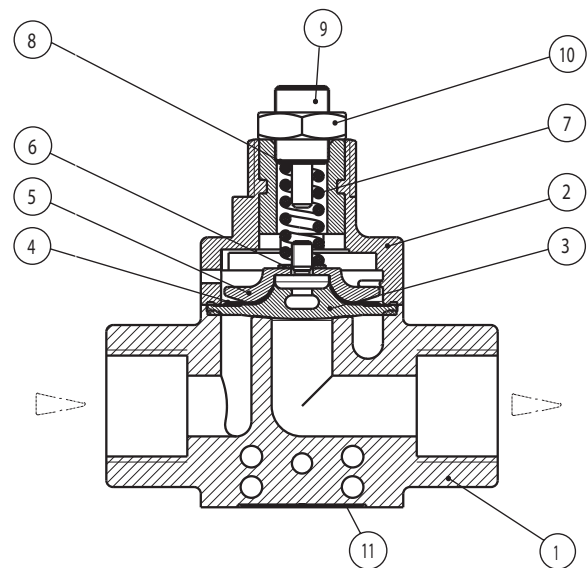

- |                      |                   |
|----------------------|-------------------|
| 1 Lower body         | 7 Pressure spring |
| 2 Upper body         | 8 Washer          |
| 3 Lip diaphragm      | 9 Spindle         |
| 4 Anti-friction ring | 10 Locknut        |
| 5 Support            | 11 Label          |
| 6 Washer             |                   |

# The KNF Modular Concept of Selection



Our versatile self-selection program allows you to personally determine the optimum characteristics which you require from your pressure control valve. Select your diaphragm pressure control valve from the following possibilities:

Maximum flow rate for liquid (l/min)	Pressure range (bar g)	Valve type			
		Basic model	Components		
			1	2	3
3	0.2 - 2.5	FDV 3_			Z
	2.0 - 6.5	FDV 1.3_			Z
12	0.8 - 2.5	FDV 30_			Z
	2.0 - 6.5	FDV 1.30_			Z

## Example of valve selection

FDV 1.31 TV Z

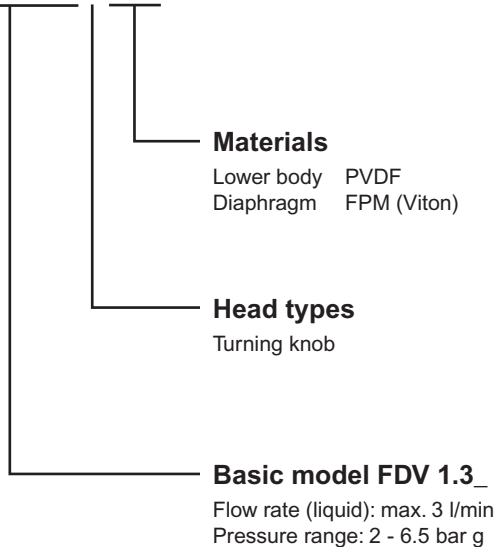

1	Head types
0	Shaft spindle / locknut
1	Turning knob

2	Materials (wetted parts)
KP	Lower body PP Diaphragm EPDM
KV	Lower body PP Diaphragm FPM (Viton)
KT	Lower body PP Diaphragm FFPM
TV	Lower body PVDF Diaphragm FPM (Viton)
TT	Lower body PVDF Diaphragm FFPM

## Note:

FDV diaphragm pressure control valves are suitable for liquid and gaseous media. When used in conjunction with pumps, please note the maximum pressure and flow values of the control valve.



## Performance

Basic model	Lowest adjust. pressure (bar g)	Highest adjust. pressure (bar g)
FDV 30/31	0.2	2.5

Basic model	FDV 30/31
Factory set working pressure (bar g)	0.5
Maximum flow rate for liquid (l/min)	3
Maximum flow rate for gas (NI/min)	150
Max. permissible temp. of media (°C)	80
Max. permissible operating temp. (°C)	80
Connecting threads	G 1/8"
Weight according to material of constr. (g)	50 - 60

## Performance

Basic model	Lowest adjust. pressure (bar g)	Highest adjust. pressure (bar g)
FDV 1.30/1.31	2	6.5

Basic model	FDV 1.30/1.31
Factory set working pressure (bar g)	3
Maximum flow rate for liquid (l/min)	3
Maximum flow rate for gas (NI/min)	150
Max. permissible temp. of media (°C)	80
Max. permissible operating temp. (°C)	80
Connecting threads	G 1/8"
Weight according to material of constr. (g)	50 - 60

### FDV 30/1.30

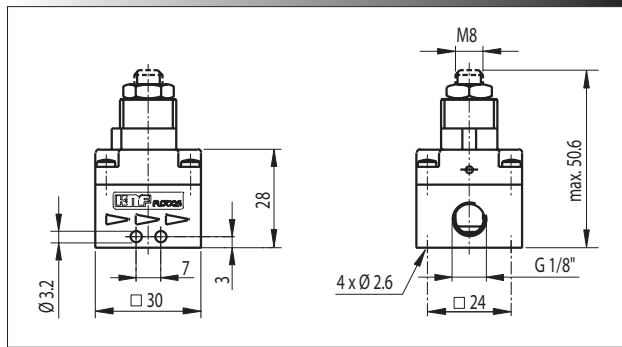

### FDV 31/1.31

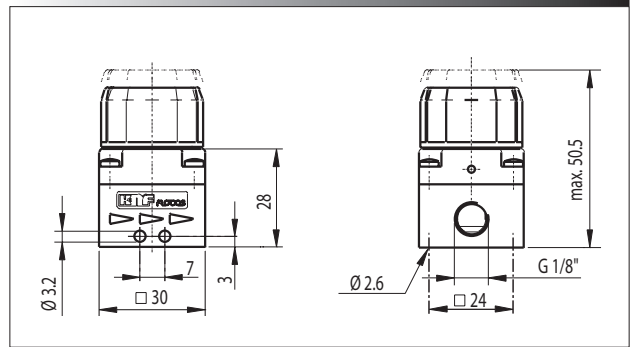

### Performance chart for liquids

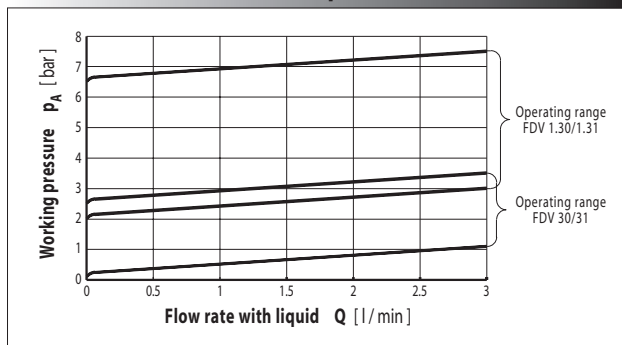

All FDV diaphragm pressure control valves are suitable for use with liquids.

### Performance chart for gases

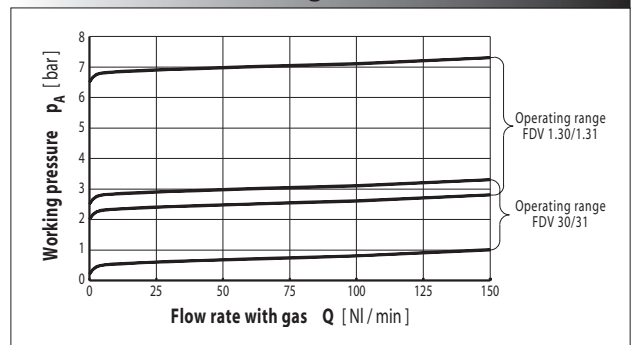

All FDV diaphragm pressure control valves are suitable for use with gases, except the KP version (EPDM diaphragm).

# FDV 300/301

# FDV 1.300/1.301



## Performance

Basic model	Lowest adjust. pressure (bar g)	Highest adjust. pressure (bar g)
FDV 300/301	0.8	2.5

Basic model	FDV 300/301
Factory set working pressure (bar g)	1
Maximum flow rate for liquid (l/min)	12
Maximum flow rate for gas (NI/min)	300
Max. permissible temp. of media (°C)	80
Max. permissible operating temp. (°C)	80
Connecting threads	G 3/8"
Weight according to material of constr. (g)	50 - 70

## Performance

Basic model	Lowest adjust. pressure (bar g)	Highest adjust. pressure (bar g)
FDV 1.300/1.301	2	6.5

Basic model	FDV 1.300/1.301
Factory set working pressure (bar g)	3
Maximum flow rate for liquid (l/min)	12
Maximum flow rate for gas (NI/min)	300
Max. permissible temp. of media (°C)	80
Max. permissible operating temp. (°C)	80
Connecting threads	G 3/8"
Weight according to material of constr. (g)	50 - 70

### FDV 300/1.300

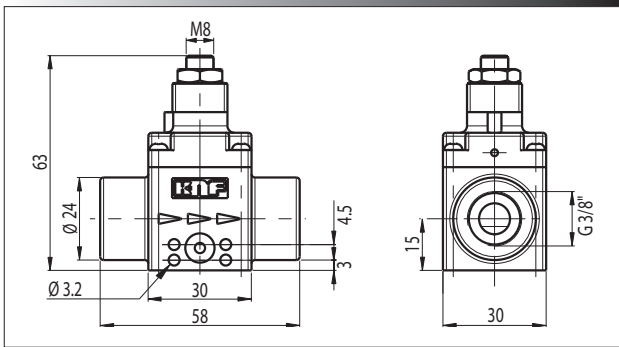

### FDV 301/1.301

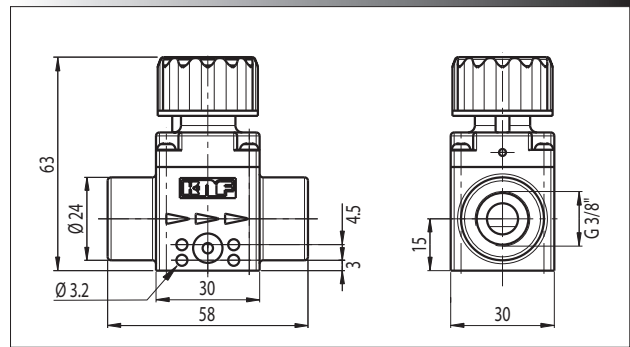

### Performance chart for liquids

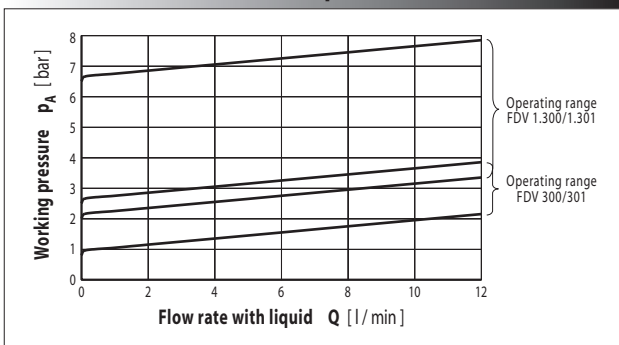

All FDV diaphragm pressure control valves are suitable for use with liquids.

### Performance chart for gases

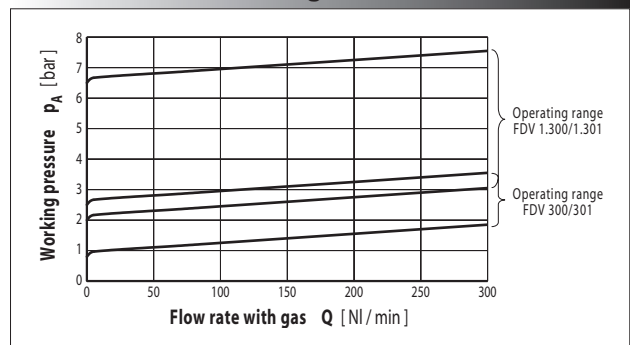

All FDV diaphragm pressure control valves are suitable for use with gases, except the KP version (EPDM diaphragm).



## Installation

The pressure control valve is supplied ready to use. The following comments advise on its correct installation:

- Mounting can be in any position.
- The pressure control valve must always be installed on the pressure side of the pump.
- The pressure control valve can be fastened in position using either the holes in the side or at the bottom of the lower body.
- Appropriate connections, tubes etc. should be checked for liquid/gas tightness.

### Pressure measurement

A pressure measuring device (manometer, sensor etc.) can be connected directly onto the pressure valve (connection port).

## Operating instructions

Careful consideration of the following instructions will improve safety and extend the service life of the pressure control valve.

- The maximum permissible pressure of the basic model should not be exceeded.
- The adjusted opening pressure of the pressure control valve should not be higher than the maximum permissible pressure of the pump or the working system.
- Head materials, together with hose connectors and tubing should be chemically resistant to any media.
- Maximum operating temperature for standard models is 80°C, maximum fluid temperature is 80°C.

## Maintenance

KNF pressure control valves operate largely without wear and tear or maintenance and thus do not require regular attention. We recommend, however, periodical checks as follows:

- Check that the mounting screws of the pressure control valve are tight.
- Check that the hose connections are liquid/gas tight.

## Applications

FDV diaphragm pressure control valves can be used for many different functions.

### Pressure control function

The FDV valve creates a constant back pressure when pumping into a system with fluctuating pressure or a vacuum or out of a system with a positive pressure. This optimises the accuracy and repeatability of the pump.

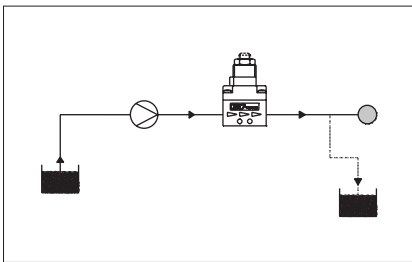

### Bypass function

The pressure control valve prevents the build up of excessive pressure on the operating side of the system and protects the pump, pipework, vessels, glassware etc.

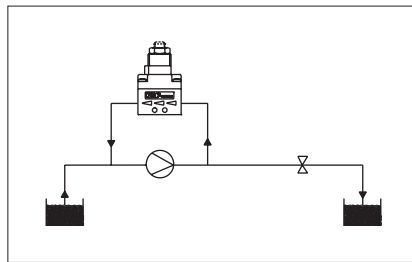

### Anti-injection function

When metering into pipework at high flow rates, the FDV valve avoids unintended injection of liquid.

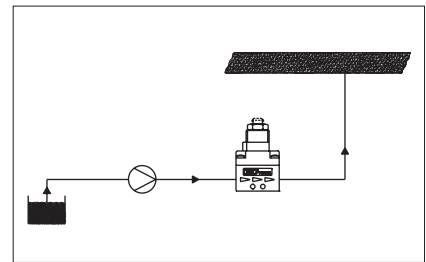

**KNF Neuberger, Inc. • 2 Black Forest Road • Trenton, NJ 08691-1810**  
**609-890-8600 • Fax 609-890-8323**  
**[www.knf.com/usa.htm](http://www.knf.com/usa.htm)**

INNOVATIVE  
TECHNOLOGY  
WORLDWIDE

