

MINI GAS SAMPLING PUMPS WITH DOUBLE DIAPHRAGM SYSTEM



N 86 AN.12 DCB

Concept

Double-diaphragm pumps from KNF are based on a simple principle: an elastic working membrane and safety membrane are held securely at their edges and moved up and down at their center by an eccentric. As a result, the working membrane moves the medium through automatic valves. The lower lying safety diaphragm provides the working diaphragm with additional security.

The safety membrane has a significantly longer service life than the working diaphragm. The redundant arrangement of the diaphragms ensures that no gas can escape into the environment even if the working diaphragm ruptures.

The KNF modular system permits selection of materials with various levels of gas resistance for parts in contact with gas. Several different motors are available to drive the pump. Please contact us for details.

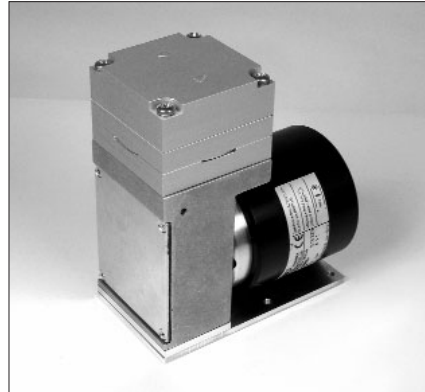

N 816 AV.12 DCB

Features

Pure transfer

No contamination of the media due to oil-free operation

Maintenance-free

Compact size

High performance

High level of gas tightness:
6 x 10⁻⁴ mbar x l/s

Long product life

Very quiet and little vibration

With brushless DC motor

Cool running motor even when in constant use, wide range speed controlled motor

Can operate in any installed position

High security against escape of hazardous or valuable gases.

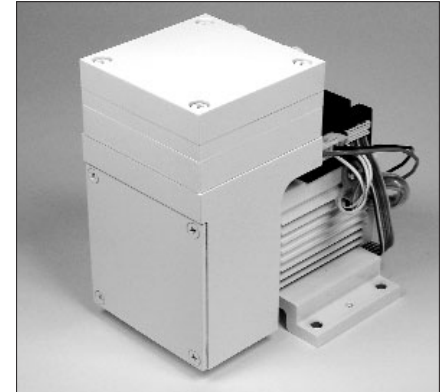

N 838 AN.12 DCB

Areas of use

The double diaphragm pumps offer a high level of performance despite their small size, as well as an excellent price performance ratio. They are required especially in the fields of analysis, process, chemical, fuel cell, production technology and research.

The pumps are used for transferring and sucking gases, taking samples (even liquids in a vacuum), evacuating vessels and compressing gases in process systems and vessels.

PERFORMANCE DATA

Type	Delivery (l/min)	Vacuum (mbar abs.)	atm. Press.	Pressure (bar g)	Weight (kg)
N 86 AN.12 DCB	4.5	250		1.0	0.7
N 816 AV.12 DCB	11	250		0.6	1.5
N 838 AN.12 DCB	25	200		0.6	2.5

N 86 AN.12 DCB

PERFORMANCE DATA

Type and Order No. ²⁾	Delivery at atm. pressure (l/min) ¹⁾	Max. operating pressure (bar g)	Ultimate vacuum (mbar abs.)
N 86 AN.12 DCB	4.5	1	250

¹⁾ Litre at STP

MODEL CODES AND MATERIALS

Type and Order No. ²⁾	Pump head	Diaphragm	Valves
N 86 AN.12 DCB	Aluminium	NBR	NBR

²⁾ See also „MODEL CODES FOR EASY ORDERING“

MOTOR DATA ³⁾

Brushless dc motor	12 V	24 V	
Operating current	0.65 A	0.35 A	

³⁾ Other motors on request.

Dimensions mm (All dimensional tolerances conform to DIN ISO 2768-1, Tolerance Class V)

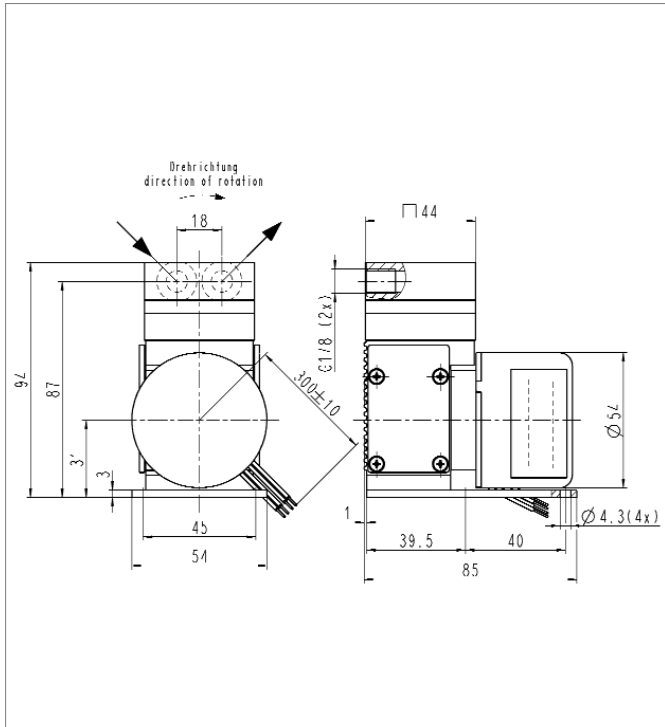

N 816 AV.12 DCB

PERFORMANCE DATA

Type and Order No. ²⁾	Delivery at atm. pressure (l/min) ¹⁾	Max. operating pressure (bar g)	Ultimate vacuum (mbar abs.)
N 816 AV.12 DCB	11	0.6	250

¹⁾ Litre at STP

MODEL CODES AND MATERIALS

Type and Order No. ²⁾	Pump head	Diaphragm	Valves
N 816 AV.12 DCB	Aluminium	FPM	FPM

MOTOR DATA ³⁾

Brushless dc motor	24 V	
Operating current	1.1 A	

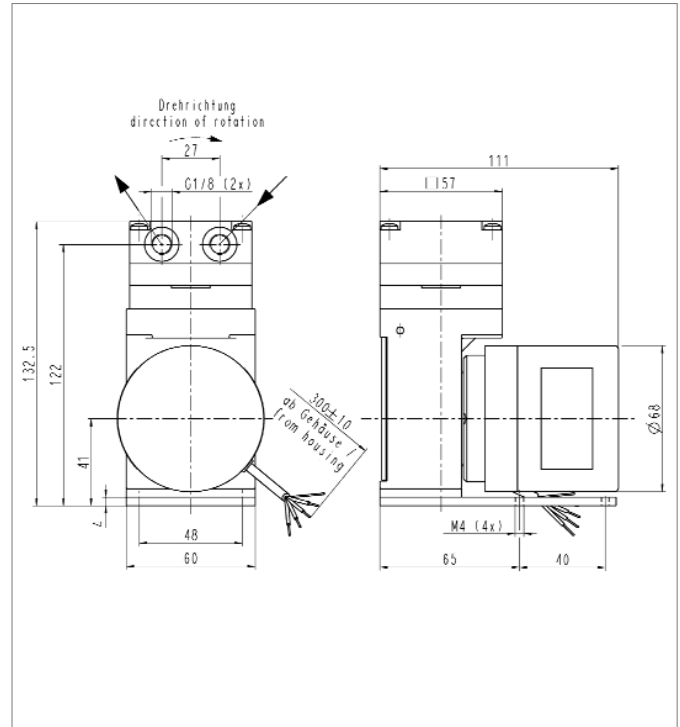

Performance characteristic

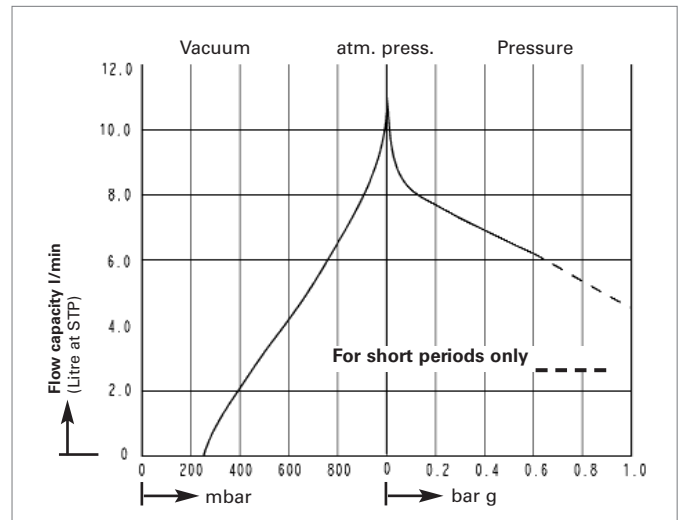
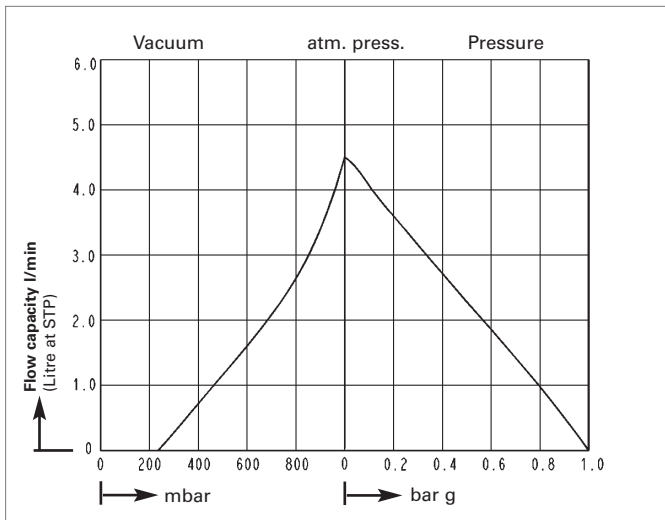

N 838 AN.12 DCB

PERFORMANCE DATA

Type and Order No. ²⁾	Delivery at atm. pressure (l/min) ¹⁾	Max. operating pressure (bar g)	Ultimate vacuum (mbar abs.)
N 838 AN.12 DCB	25	0.6	200

¹⁾ Litre at STP

MODEL CODES AND MATERIALS

Type and Order No. ²⁾	Pump head	Diaphragm	Valves
N 838 AN.12 DCB	Aluminium	NBR	NBR

MOTOR DATA ³⁾

Brushless dc motor	24 V	
Operating current	1.9 A	

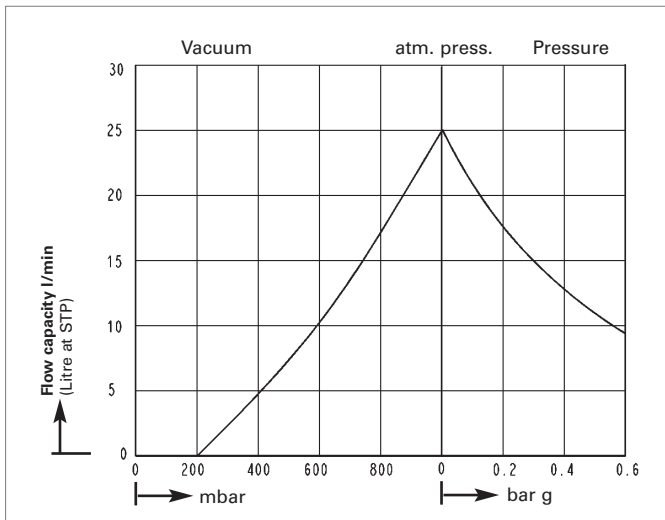
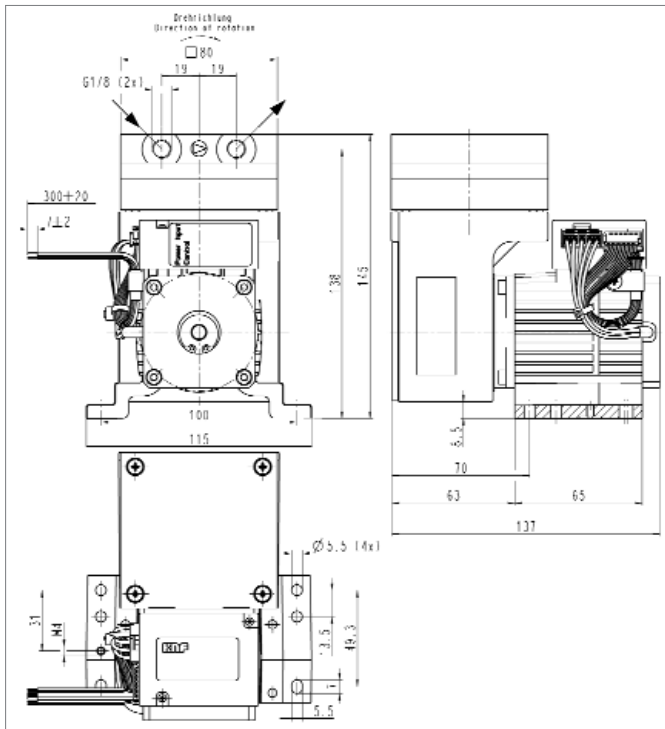

TECHNICAL INFORMATION

Pump down time for 5 l receiver

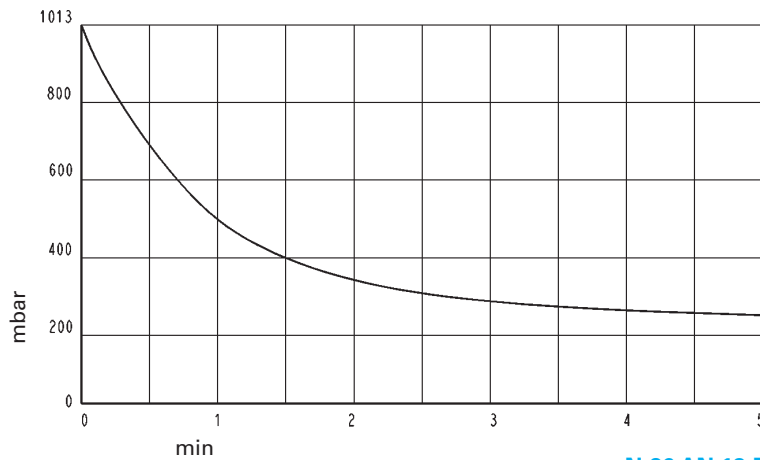

N 86 AN.12 DCB

MODEL CODE FOR EASY ORDERING

The model code is identical to the order number. It is made up as follows:

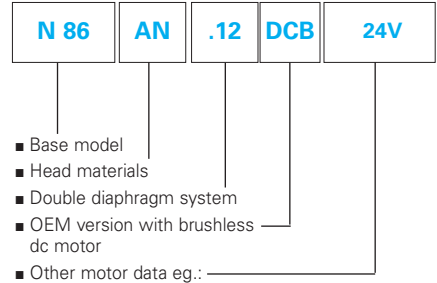

In our extensive program you are sure to find the pump you need for your particular application.

Pump down time for 5 l receiver

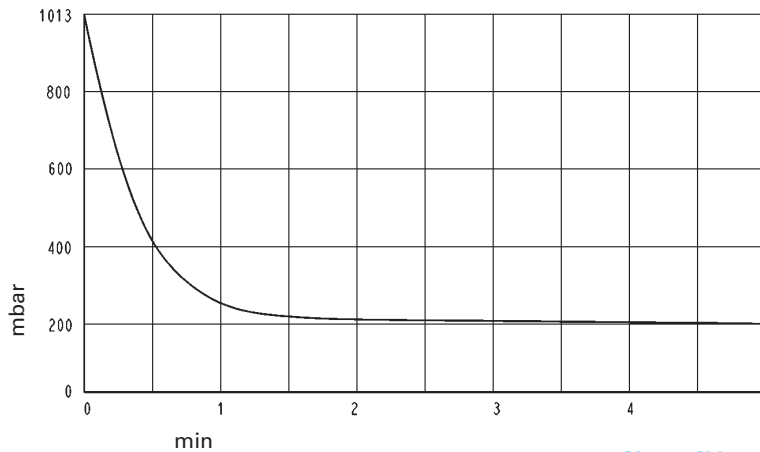

N 816 AV.12 DCB

TECHNICAL DETAILS

Observe all information in the operating instructions in order to maintain CE conformity and compliance with EMC directives according to EN 55014-1.

Motors with other voltages and frequencies on request.

Pump down time for 20 l receiver

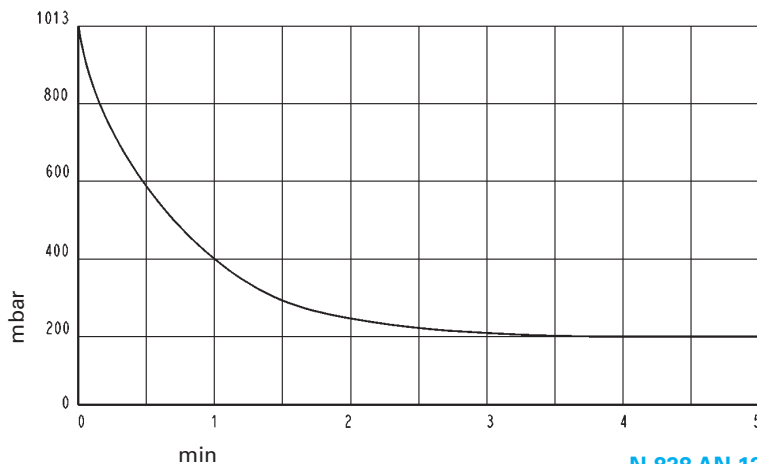

N 838 AN.12 DCB

KNF Neuberger Inc.

Two Black Forest Road
Trenton, New Jersey 08691-1810
Phone: 609-890-8600
Fax: 609-890-8323
www.knf.com