

## CHEMICALLY RESISTANT DIAPHRAGM PUMP WITH KNF STABILIZATION SYSTEM

Section 60.15

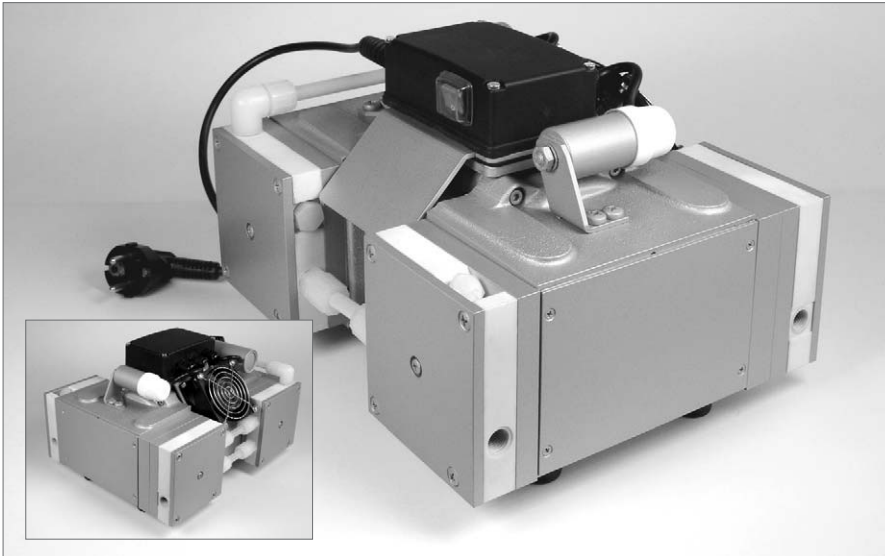

N 940.5TTE as AC version in IP 54 (main picture). Inset picture shows the rear view, with the special cooling fan visible.

### Concept

The powerful diaphragm vacuum pumps N940 series are especially well suited for all applications requiring excellent suction speed with low absolute pressures. A series of technical innovations, including a diaphragm stabilization system, allows the high suction especially in the low-vacuum range.

Thanks to the KNF modular system, the parts used to transfer the gases can be made from materials with varying degrees of durability. The customer has a choice of pump drives ranging from a selection of voltage and frequency. The explosion-proof models to ATEX, please contact us for further details.

### Features

#### Transferring and evacuation of air and gases

No contamination of the media due to oil-free operation

**Optimized suction speed,** also for low absolute pressures thanks to KNF stabilization system

**High level of gas tightness** thanks to the closed diaphragm surface and special sealing system

#### Quiet running

**Cool and efficient brushless motor**

**Can operate in any installed position**

### Areas of use

The Diaphragm Vacuum Pump N940 series offer a high level of performance, as well as an excellent price performance ratio. The pumps are used for transferring, compressing and evacuating air, gases and vapours, taking samples and evacuating vessels and systems.

The chemically-resistant vacuum pumps are required especially in the fields of analytical applications, the process engineering and production technology.

There are many applications for the N940 series, please contact KNF for application advice.

## PERFORMANCE DATA

Type	Delivery (l/min)	Vacuum (mbar absolute)	atm. Press.	Pressure (bar g)	Weight (kg)
N 940.5TTE	48	2		0,5	18,6

### PERFORMANCE DATA

Type and Order No.	Delivery (l/min) <sup>1)</sup> at atm. pressure	Max. operating pressure (bar g)	Ultimate vacuum (mbar abs.)
N 940.5 TTE	48	0.5	2

<sup>1)</sup> Litre at STP

### MODEL CODES AND MATERIALS

Type and Order No.	Pump head	Diaphragm	Valves
N 940.5 TTE	PTFE/PVDF	PTFE	FFPM

### MOTOR DATA

Motor type: AC version		
Protection class	IP 54	
Voltage/Frequencies (V/Hz)	230/50	115/60
Power P <sub>1</sub> (W)	250	250
Operating current (A)	1.7	~3.5

Motors with other voltages, frequencies and protection classes on request.

Dimensions mm (All dimensional tolerances conform to DIN ISO 2768-1, Tolerance Class V)

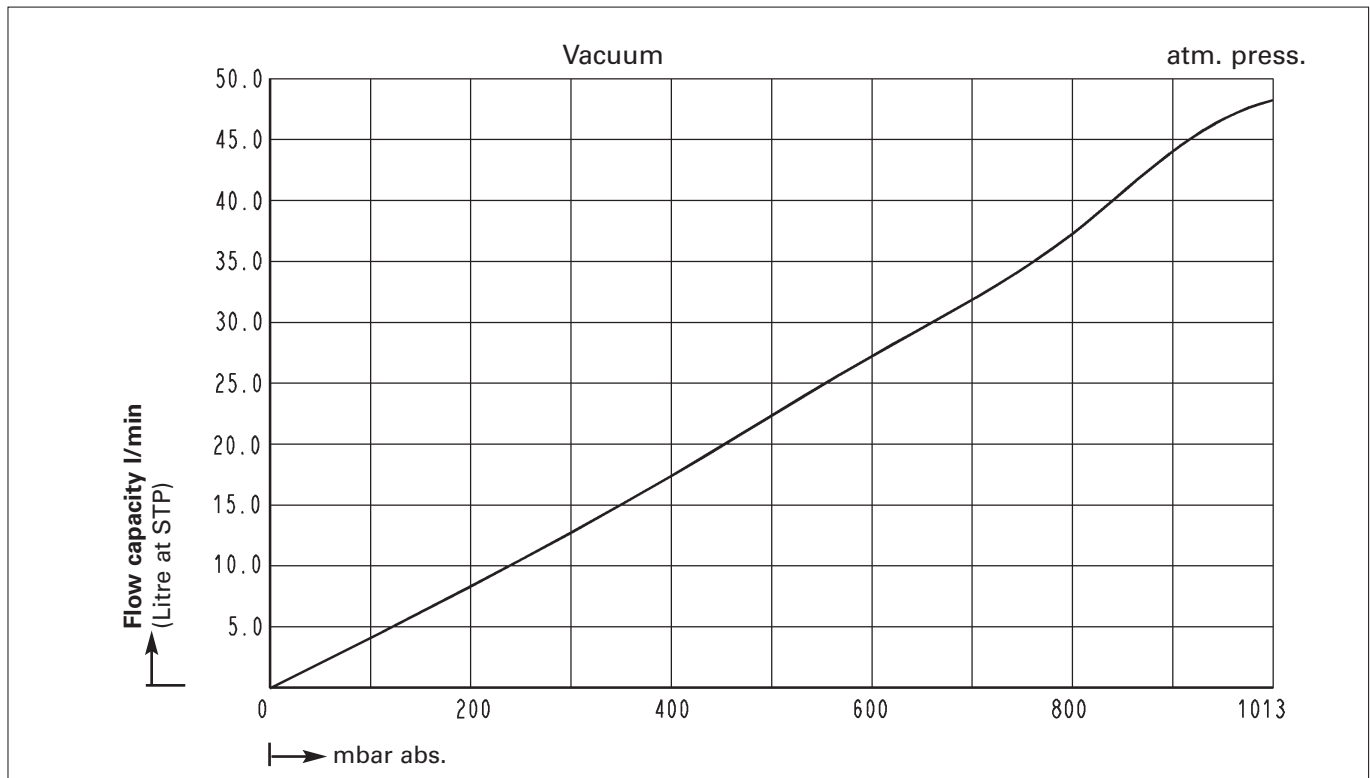
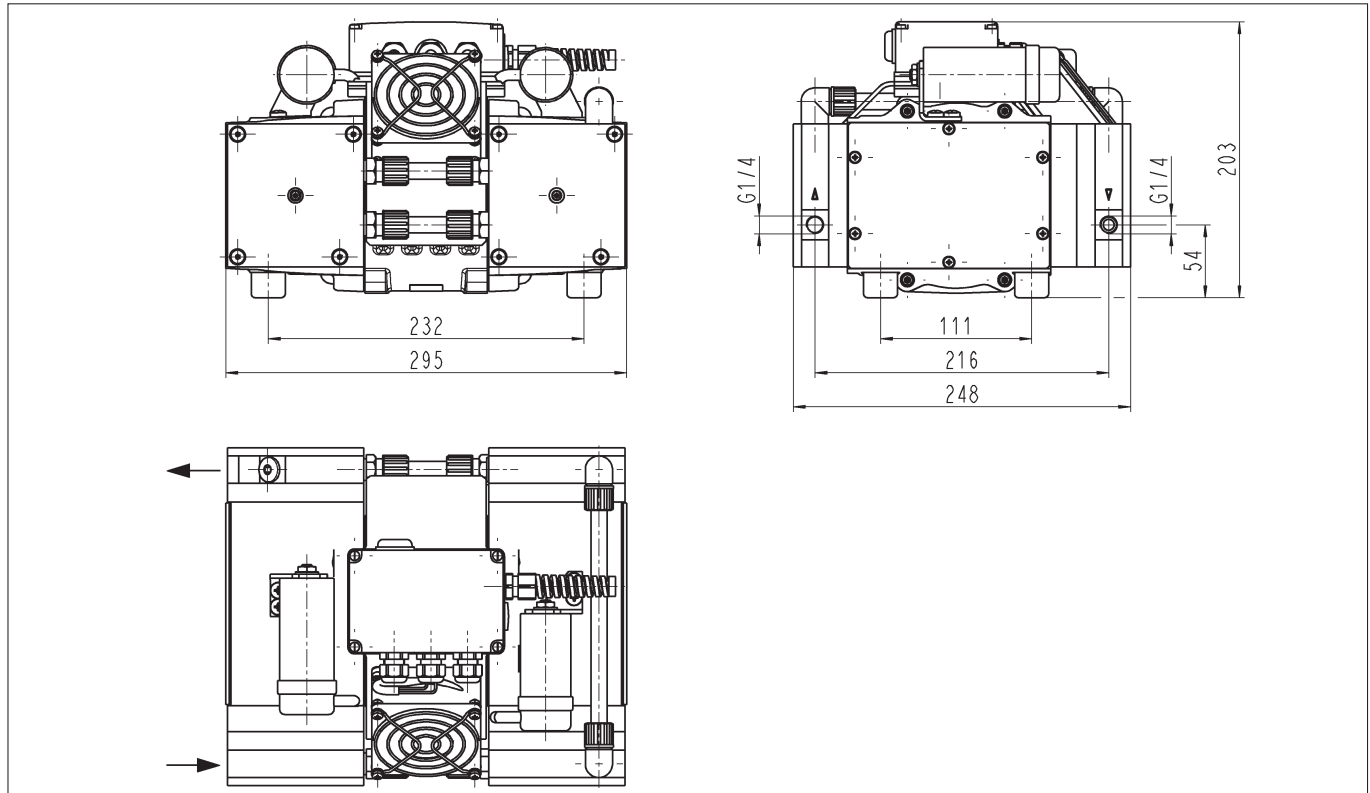

# PERFORMANCE DATA

## Suction pumping speed

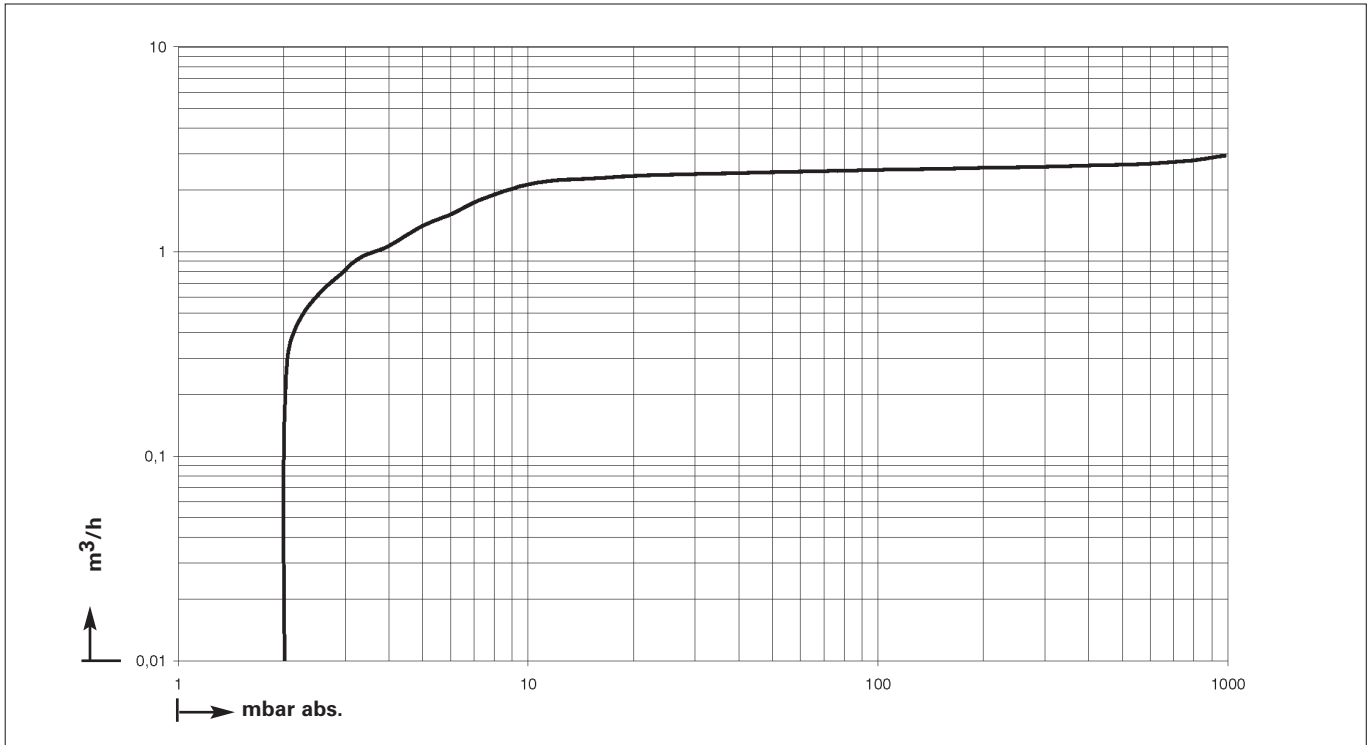

## Pump down time for 20 litre receiver, driving speed 1500 1/min

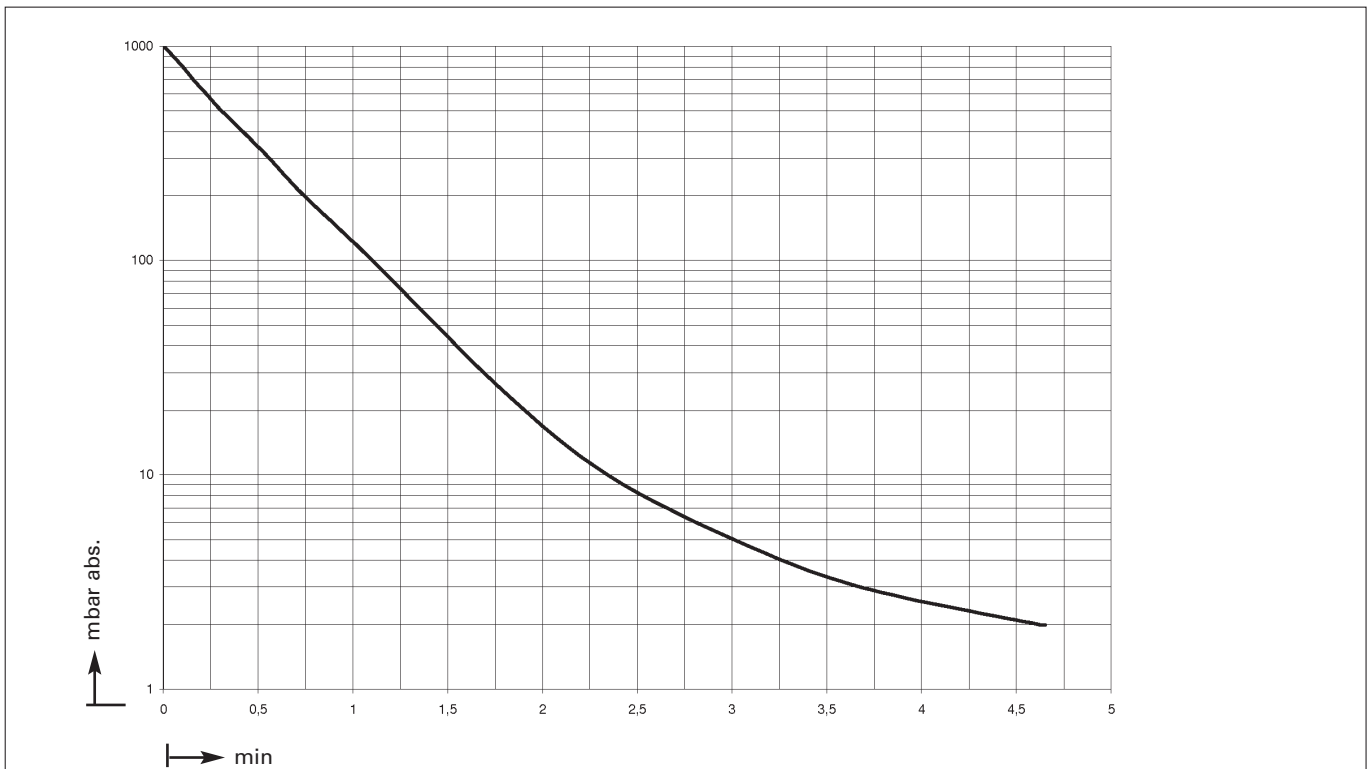

# FUNCTION, INSTALLATION AND SERVICE

## THE BASIC FUNCTION OF KNF DIAPHRAGM VACUUM PUMPS AND COMPRESSORS

An elastic diaphragm is moved up and down by an eccentric (see illustration). On the down-stroke it draws the air or gas being handled through the inlet valve. On the up-stroke the diaphragm forces the medium through the exhaust valve and out of the head. The compression chamber is hermetically separated from the drive mechanism by the diaphragm. The pumps transfer, evacuate and compress completely oil-free.

### Diaphragm pump

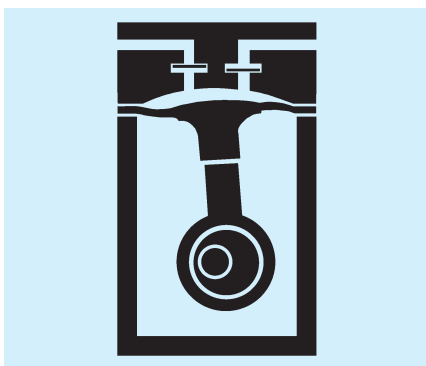

## HINTS ON INSTALLATION AND OPERATION

- Range of use: Transferring air and gases at temperatures between + 5 °C and + 40 °C
- Permissible ambient temperature: between + 10 °C and + 40 °C
- Standard pumps are not suitable for use in areas where there is a risk of explosion. In these cases there are other products in the KNF program - please ask us for details
- To prevent the maximum operating pressure being exceeded, restriction or regulation of the air flow should only be carried out in the suction line
- Components connected to the pump must be designed to withstand the pneumatic performance of the pump

- Install the pump so that the fan can draw in sufficient cooling air
- Fit the pump at the highest point in the system, so that condensate cannot collect in the head of the pump.

## HINTS ON SERVICE

The diaphragm and valves are the only parts of the KNF diaphragm pumps subject to wear. They are easy to change, as no special tools are needed.

If you have any questions, please call our application engineers (see below for contact telephone number)

### KNF Neuberger Inc.

2 Black Forest Road  
Trenton, New Jersey 08691  
Tel. 609-890-8600  
Fax 609-890-8323

www.knf.com

Please visit our website at [www.knf.com](http://www.knf.com) for further information.

## Diaphragm stabilization system

An additional diaphragm, the stabilization diaphragm, separates the underside of the working diaphragm from the "crank" space of the pump (see Fig. 2). The space between the two diaphragms (called a vacuum chamber) is connected with the suction side of the pump via an balancing connection. This

way, the vacuum chamber has approximately the same pressure as the working space of the diaphragm pump. The pressure difference between the upper and underside of the diaphragm approaches zero. The working diaphragm remains stable, independent of the inlet pressure of the pump. This

improves the suction speed of the pump significantly, over its entire working range.

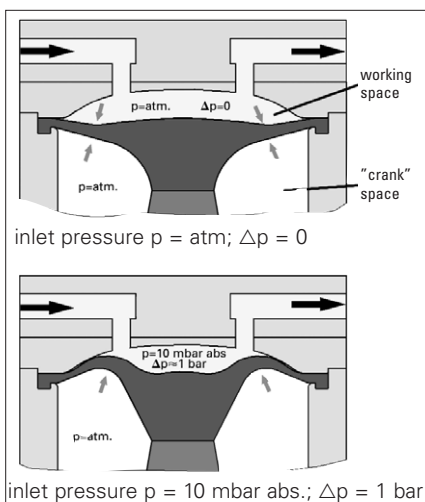

Fig. 1: Diaphragm behavior, due to the pressure difference between working space and "crank" space (normal diaphragm pump)

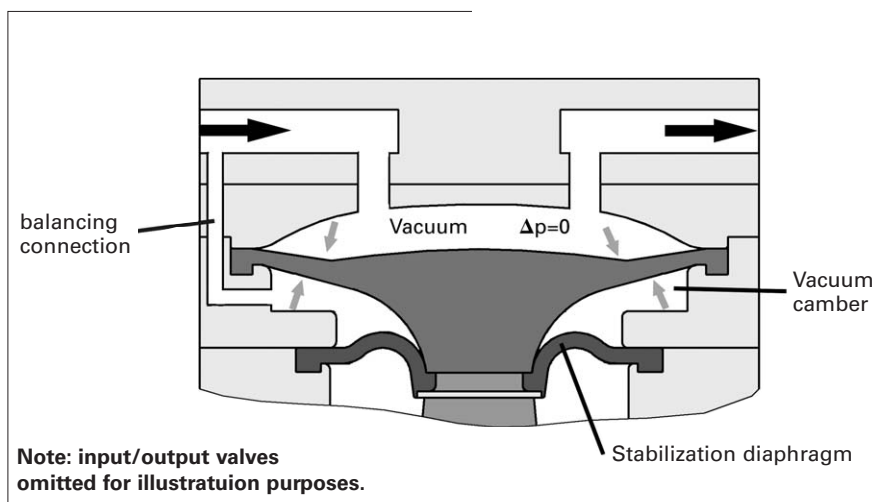

Fig. 2: Diaphragm stabilization system with additional diaphragm. This improves the suction speed of the pump significantly, over its entire working range.