

MICRO DIAPHRAGM LIQUID PUMPS NF 10/11

SECTION 200.15



Concept

KNF micro diaphragm liquid pumps are based on the principle of the oscillating displacement pump which is remarkably simple in design. The circular power from the motor is converted into vertical movement by an eccentric. This motion is then transferred to a diaphragm by means of a connecting rod which in conjunction with an inlet and outlet valve creates a pumping action.

NF 10/11 type liquid pumps can be mounted in any position and can deliver up to 0.1 l/min depending on the model and will operate against pressures of up to 14.5 PSIG.

The KNF modular system contains a wide standard range of materials, motors, voltages and frequencies to enable the selection of an optimal solution for your application.

Features

Small and powerful

Micro design and maximum performance resulting from built-in technology are the outstanding characteristics of this product.

Self-priming and excellent for pressure

Sophisticated diaphragm technology and precise valve structures enable performances of up to 8.85 in.Hg suction and 14.5 PSIG pressure.

Extreme chemical resistance

The use of chemically resistant materials such as PTFE, PVDF, FFPM or other material combinations for the parts which come in contact with the liquid allows almost all neutral or corrosive liquids to be pumped.

Dry running, durable and maintenance free

The carefully considered design of these pumps allows them to be run dry and ensures safe operation and a long life even under the most severe conditions.

Areas of use

The versatility of KNF pumps allows a wide field of applications to be covered. Over many years our pumps have proved themselves in the following areas:

Analysers

- Medical / pharmaceutical
- Environmental / water treatment
- Food / toxicology

Laboratory

- Filtration
- Chromatography

Cleaning industry

- Cuvette cleaning
- Sterilisers
- Industrial washing machines

Printing

- Ink jet printing
- Photographic / film development

Other applications for diaphragm liquid pumps include: fuel cells, hydrogen generators, CD coating, dental technology, textiles and many more.

Performance Data

Type	Flow rate (l/min)	Suction head (in. Hg)	Pressure head (PSIG)
NF 10/11	0.1	8.85	14.5

The KNF Modular Concept of Selection

General note

This Data Sheet provides an overview of the options with our NF 10/11 pumps. Certain standard options will be explained in more detail where necessary.

Flow curves

The flow curves illustrate how the flow rate alters in relation to the pressures before and after the pump. In the case of a combination of both we would be very happy to advise what the expected flow rate would be.

The values given in the curves are dependant upon the liquid, choice of head materials and the type of hoses being used. Therefore a certain deviation is to be expected.

Note: The flow rate is measured with water at 20°C.

1 Materials of head components

KNF FLODOS offers a wide range of different materials for those parts which come in contact with the liquid thus allowing the possibility of pumping most liquids.

2 Motors

DC Direct current motor

NF 11 Ironless direct current motor
This provides the following advantages compared to a conventional DC motor: higher durability, less power consumption and smaller size.

DCB Brushless direct current motor
This type of motor has no brushes which can wear down thus giving it a higher lifetime and no brushes fire.
Option with four leads (motor speed control and rpm. impulse output.)

3 Voltages

Choose from the different electrical connection possibilities. Special variations are available.

Modules

Our versatile self-selection program allows you to personally determine the optimum characteristics that you require from your pump. Select your diaphragm pump from the following characteristics:

Pump type			
Basic model	Components		
	1	2	3
NF 10/11			

1	Materials of head components	
KP / KP .51*	Head	PP
	Valves	EPDM
	Diaphragm	EPDM
	Resonating diaphragm	EPDM
KV	Head	PP
	Valves	FPM
	Diaphragm	FPM
	Resonating diaphragm	FPM
KT	Head	PP
	Valves	FFPM
	Diaphragm	PTFE
	Resonating diaphragm	FFPM
TV	Head	PVDF
	Valves	FPM
	Diaphragm	FPM
	Resonating diaphragm	FPM
TT	Head	PVDF
	Valves	FFPM
	Diaphragm	PTFE
	Resonating diaphragm	FFPM

* food conform according to the standard NSF/ANSI 169, for further information see options

2	Motors
DC	Direct current motor
DCB	Brushless direct current motor

3	Voltages
6/12/24V	for DC motors
12/24V	for DCB motors

NF 10-DCB / NF 11-DC

NF 10-DC

Performance

Basic model	Flow rate at atmos. pressure (l/min)	Max. suction head (in. Hg)	Max. pressure head (PSIG)
NF 10-DCB	0.1	8.85	14.5
NF 10-DC	0.1	8.85	14.5

Motor selection	DCB (NF10)	DC (NF11)
Voltage (V)	12 / 24	6 / 12 / 24
Power rating (W)	1.7	2.2 / 2.5 / 2.3
Current (A)	0.14 / 0.07	0.33 / 0.17 / 0.08
I max. (A)	0.45	0.37 / 0.21 / 0.09
EMI guideline	EN 61000-6-2 EN 61000-6-3	EN 55022 EN 55011
Weight (g)	56	70
Motor protection factor	IP 40	IP 33

NF 10-DCB

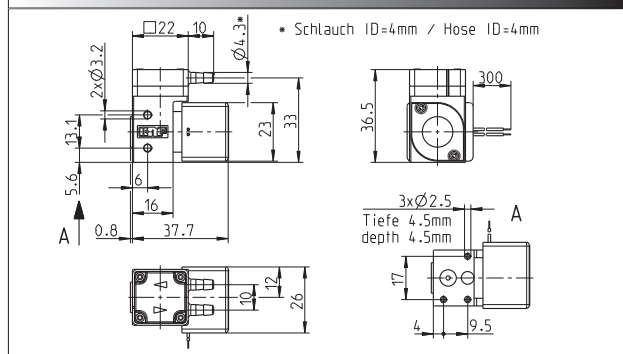

Performance

Basic model	Flow rate at atmos. pressure (l/min)	Max. suction head (in. Hg)	Max. pressure head (PSIG)
NF 10-DC	0.1	8.85	14.5

Motor selection	DC (NF10)
Voltage (V)	6 / 12 / 24
Power rating (W)	3.8 / 3.7 / 3.4
Current (A)	0.61 / 0.25 / 0.13
I max. (A)	0.64 / 0.31 / 0.14
EMI guideline	EN 55022 EN 55011
Weight (g)	60
Motor protection factor	IP 30

NF 10-DC

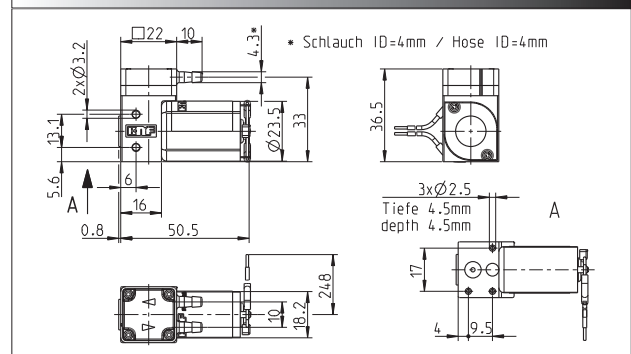

NF 11-DC

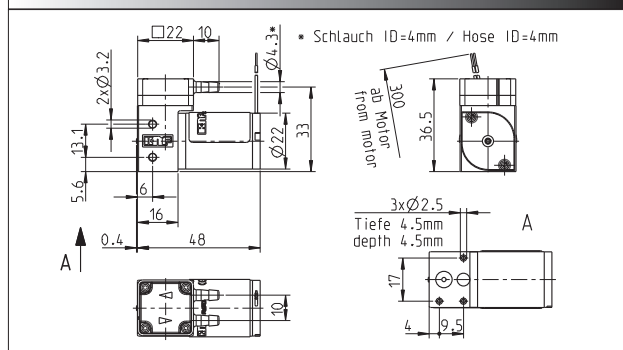

Flow curve NF 11-DC / NF 10-DCB

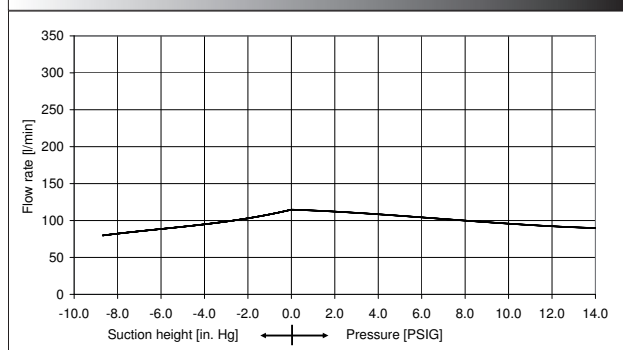

Flow curve NF 10-DC

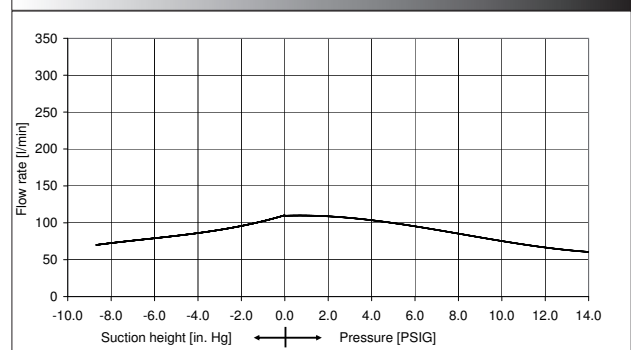



Diaphragm pressure control valve

The pressure control valve can be used for a more accurate control of flow against a fluctuating back pressure, metering into a vacuum and from a pressurised system. Used correct it can save pumps, plumbings and other fittings from damage.



Pulsation damper

This very versatile pulsation damper reduces the vibration in hoses and pipes and it helps to remove pulsation which is preventing the system from functioning correctly. It also protects instrumentation connected after the pump.

Further accessories

- Hoses
- Hoses connections
- Shock mounts

NSF National Sanitary Foundation

NSF is market leader in the development and controlling of standards relevant for equipment used for handling foodstuffs. By using different toxicological tests our products will be certified according to the standard NSF/ANSI 169. This certification will confirm that all of the pumps with the code .51 are certified for the use with foods/consumables. In addition to this it also means that the pumps are constructed with wetted parts which come with a FDA* declaration of conformity. A yearly audit from NSF will be carried out to ensure that these standards are being maintained. A list of the various products are available on request.

* FDA = Food and Drug Administration

Further options

- Special hose connections: UNF 1/4"-28, compression fitting for ID 4mm; OD 6mm hosing
- Suitable for pressures over 14.5 PSIG
- Other head materials
- Motors with special voltages and frequencies
- The incorporation of customers special requirements, or example special electrical connections (Molex, AMP, etc.)

KNF NEUBERGER, INC.

Two Black Forest Road
Trenton, New Jersey 08691-1810
Phone: 609-890-8600 Fax: 609-890-8323
Web: <http://www.knf.com/liquid>