

MICRO DIAPHRAGM LIQUID PUMPS

NF 30

SECTION 200.20



Concept

KNF micro diaphragm liquid pumps are based on the principle of the oscillating displacement pump which is remarkably simple in design. The circular power from the motor is converted into vertical movement by an eccentric. This motion is then transferred to a diaphragm by means of a connecting rod which in conjunction with an inlet and outlet valve creates a pumping action.

NF 30 type liquid pumps can be mounted in any position and can deliver up to 0.3 l/min depending on the model and will operate against pressures of up to 14.5 PSIG.

The KNF modular system contains a wide standard range of materials, motors, voltages and frequencies to enable the selection of an optimal solution for your application.

Features

Small and powerful

Micro design and maximum performance resulting from built-in technology are the outstanding characteristics of this product.

Self-priming and excellent for pressure

Sophisticated diaphragm technology and precise valve structures enable performances of up to 17.7 inHg suction and 14.5 PSIG pressure.

Extreme chemical resistance

The use of chemically resistant materials such as PTFE, PVDF, FFPM or other material combinations for the parts which come in contact with the liquid allows almost all neutral or corrosive liquids to be pumped.

Dry running, durable and maintenance free

The carefully considered design of these pumps allows them to be run dry and ensures safe operation and a long life even under the most severe conditions.

Areas of use

The versatility of KNF pumps allows a wide field of applications to be covered. Over many years our pumps have proved themselves in the following areas:

Analysers

- Medical / pharmaceutical
- Environmental / water treatment
- Food / toxicology

Laboratory

- Filtration
- Chromatography

Cleaning industry

- Cuvette cleaning
- Sterilisers
- Industrial washing machines

Printing

- Ink jet printing
- Photographic / film development

Other applications for diaphragm liquid pumps include: fuel cells, hydrogen generators, CD coating, dental technology, textiles and many more.

Performance Data			
Type	Flow rate (l/min)	Suction head (inHg)	Pressure head (PSIG)
NF 30	0.3	17.7*	14.5
NFB 30	2 x 0.3	17.7*	14.5

* for versions with PTFE diaphragm max. 14.7 inHg

The KNF Modular Concept of Selection



Our versatile self-selection program allows you to personally determine the optimum characteristics that you require from your pump. Select your diaphragm pump from the following characteristics:

Flow rate at atmos. pressure (l/min)	Max suction head (inHg)	Max. pressure head (PSIG)	Pump type				
			Basic model	Components			
				1	2	3	4
0.3	17.7	14.5	NF 30				
2 x 0.3	17.7	14.5	NFB 30				

1	Materials of head components	
KP / KP .51*	Head	PP
	Valves	EPDM
	Diaphragm	EPDM
	.27 Diaphragm	EPDM
KV	Head	PP
	Valves	FPM
	Diaphragm	FPM
	.27 Diaphragm	FPM
KT**	Head	PP
	Valves	FFPM
	Diaphragm	PTFE
	.27 Diaphragm	FFPM
TV	Head	PVDF
	Valves	FPM
	Diaphragm	FPM
	.27 Diaphragm	FPM
TT**	Head	PVDF
	Valves	FFPM
	Diaphragm	PTFE
	.27 Diaphragm	FFPM
FT	Head	PTFE
	Valves	FFPM
	Diaphragm	PTFE

2	Head types
	Standard model
.27	Integrated overpress relief valve

3	Motors
E	Shaded pole motor (AC)
DC	Direct current motor
DCB	Brushless direct current motor
DCB-A	Compact brushless direct current motor

4	Voltages / Frequencies
230V / 50Hz 115V / 60Hz 100V / 50-60Hz	for AC motors
6 / 12 / 24V	for DC motors
12 / 24V	for DCB motors

* food grade conformity according to the standard NSF/ANSI 169, for further information see options

**NFB is only in this versions as standard available. Other versions on request.

Basic models



General note

This Data Sheet provides an overview of the options with our NF 30 pumps. Certain standard options will be explained in more detail where necessary.

Flow curves

The flow curves illustrate how the flow rate alters in relation to the pressures before and after the pump. In the case of a combination of both we would be very happy to advise what the expected flow rate would be.

The values given in the curves are dependant upon the liquid, choice of head materials and the type of hoses being used. Therefore a certain deviation is to be expected.

Note: The flow rate is measured with water at 20°C.

Basic models

- NF Single headed diaphragm liquid pump
- NFB Double headed diaphragm liquid pump

1 Materials of head components

KNF FLODOS offers a wide range of different materials for those parts which come in contact with the liquid thus allowing the possibility of pumping most liquids.

2 Head types

- Standard

The pump head of the NF 30 is made up of six main parts. The diaphragm, intermediate plate, connection plate and the valves are the only parts which come in contact with the liquid. The materials which are available as standard can be seen in the table.

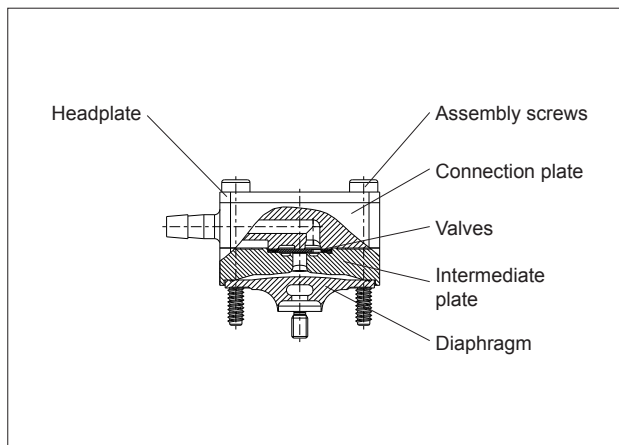

.27 Integrated overpressure relief valve

The integrated overpressure relief valve is available for all NF 30 pumps.

How it works

If the pump runs against a closed system the pressure will increase rapidly thus exceeding the allowed limits. In order to prevent this from happening a relief valve has been integrated into the head. Should the pressure exceed the adjusted value (min. 7.2 PSIG), the valve will open allowing the liquid to pass through the built-in bypass from the outlet to the inlet side.

Note: The valve is adjusted in the factory to a standard value of 21.7 PSIG.

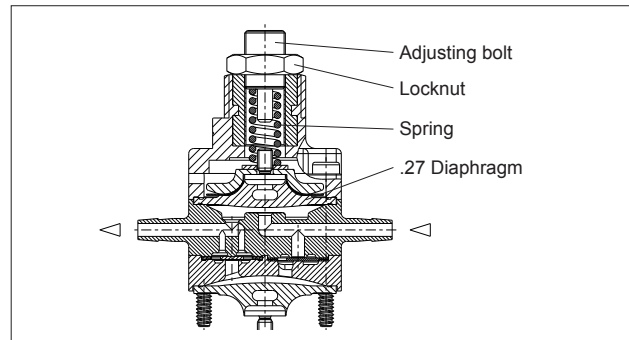

Areas of use

The valve can be used to prevent damage from occurring to the pump itself, hoses, valves and the system as a whole due to excessive pressures which can build up because of blockages or faulty valves.

3 Motors

- E Shaded pole motor (AC)
- DC Direct current motor
- DCB Brushless direct current motor
 - This type of motor has no brushes which can wear down thus giving it a lifetime comparable with an AC motor.
 - Option: control possibility via PWM or 0-5V DC signal
- DCB-A Compact brushless direct current motor
 - Reverse polarity protection
 - Overload protection
 - Thermal fuse

4 Voltages / Frequencies

Choose from the different electrical connection possibilities. Special variations are available.

NF 30 E

NF 30 DC



Performance

Basic model	Flow rate at atmos. pressure (l/min)	Max. suction head (inHg)	Max. pressure head (PSIG)
NF 30 E	0.25	17.7 ¹⁾	14.5

¹⁾ For models with PTFE diaphragm: max. 14.7 inHg

Motor selection	E
Voltage (V)	230V / 50Hz
Power rating (W)	26
I max. load (A)	0.21
I max. (A)	0.22
EMC guideline	EN 55014
Weight (g)	570
Motor protection factor	IP 00

NF 30 E

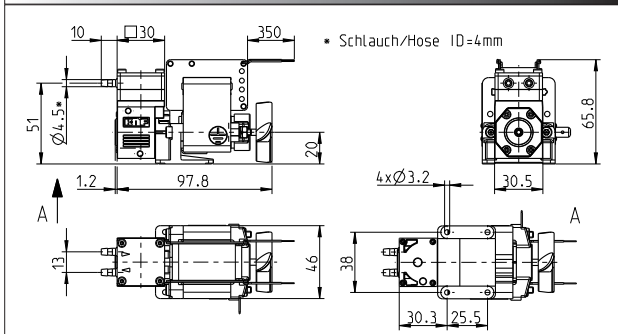

Performance

Basic model	Flow rate at atmos. pressure (l/min)	Max. suction head (inHg)	Max. pressure head (PSIG)
NF 30 DC	0.3	17.7 ¹⁾	14.5

¹⁾ For models with PTFE diaphragm: max. 14.7 inHg

Motor selection	DC
Voltage (V)	6 / 12 / 24
Power rating (W)	7.5 / 8.3 / 8.6
I max. load (A)	1.25 / 0.69 / 0.36
I max. (A)	1.88 / 0.99 / 0.51
EMC guideline	EN 55014
Weight (g)	180
Motor protection factor	IP 00

NF 30 DC

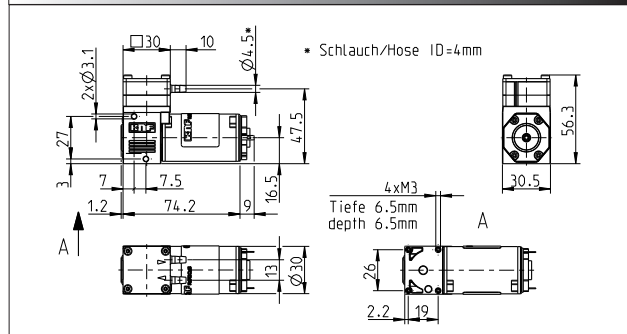

NF 30 .27E

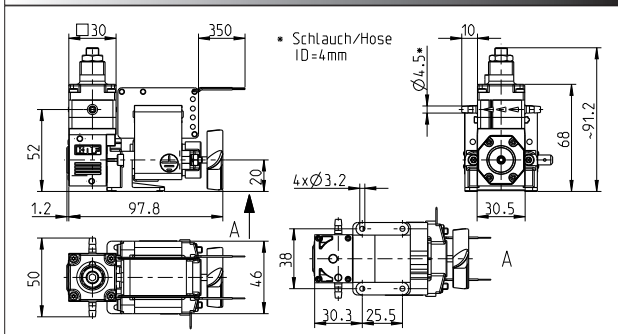

NF 30.27 DC

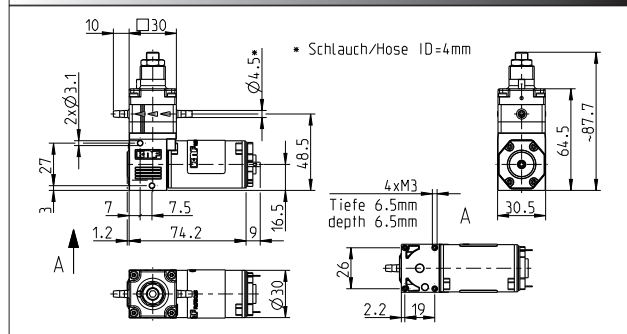

Flow curve NF 30-E

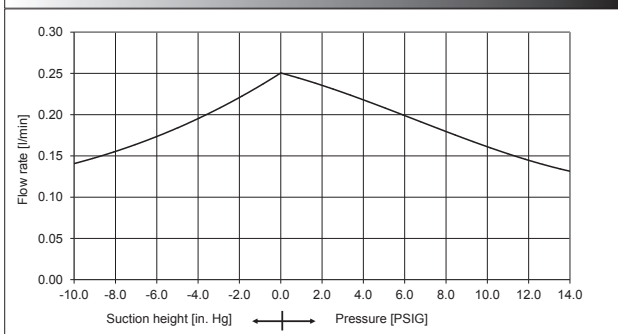

Flow curve NF 30 DC

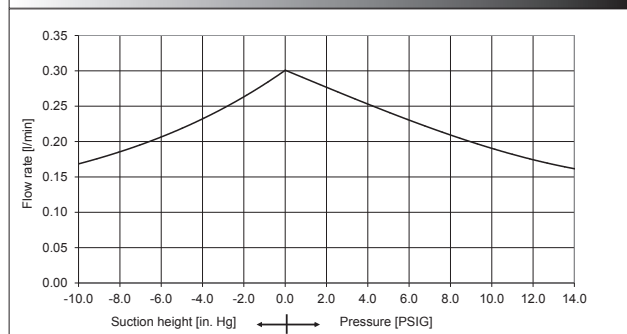

NF 30 DCB

NF 30 DCB-A



Performance

Basic model	Flow rate at atmos. pressure (l/min)	Max. suction head (inHg)	Max. pressure head (PSIG)
NF 30 DCB	0.3	17.7 ¹⁾	14.5

¹⁾ For models with PTFE diaphragm: max. 14.7 inHg

Motor selection	DCB
Voltage (V)	12 / 24
Power rating (W)	7.2 / 7.4
I max. load (A)	0.6 / 0.31
I max. (A)	0.93 / 0.46
EMC guideline	EN 55014-1 EN 61000-2-6
Weight (g)	270
Motor protection factor	IP 30

²⁾ In order to comply with the above standards attention must be paid to the specifications in the operating instructions.

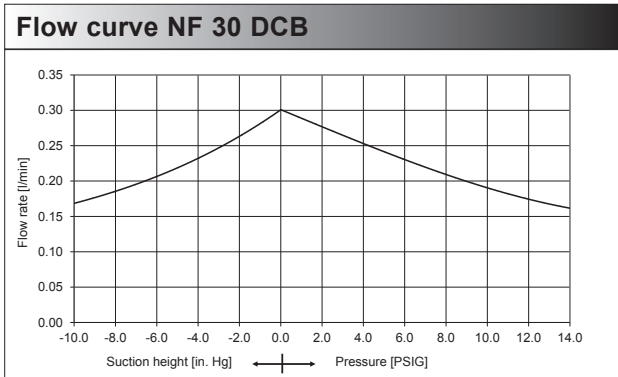
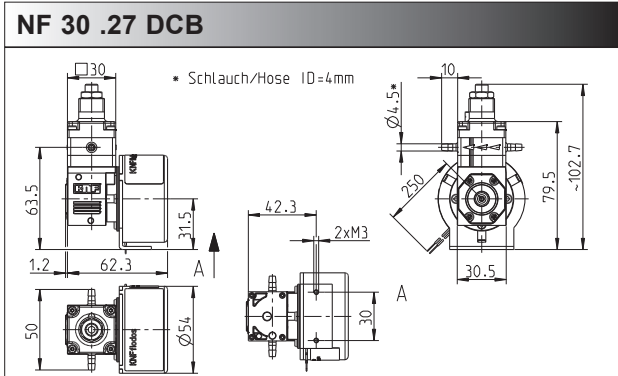
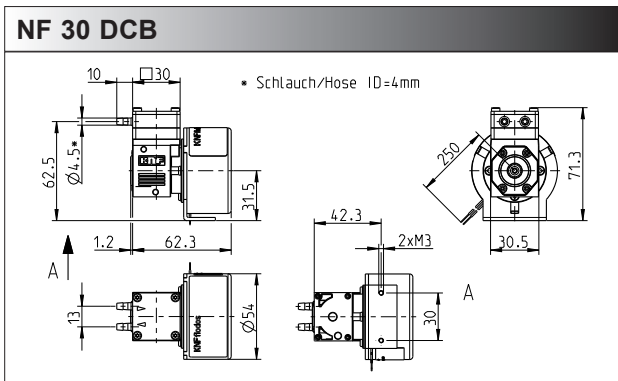

Performance

Basic model	Flow rate at atmos. pressure (l/min)	Max. suction head (inHg)	Max. pressure head (PSIG)
NF 30 DCB-A	0.3	17.7 ¹⁾	14.5

¹⁾ For models with PTFE diaphragm: max. 14.7 inHg

Motor selection	DCB-A
Voltage (V)	12 / 24
Power rating (W)	6.1 / 6.7
I max. load (A)	0.51 / 0.28
I max. (A)	1.8 / 0.9
EMC guideline	EN 55022 EN 55011
Weight (g)	170
Motor protection factor	IP 54

²⁾ In order to comply with the above standards attention must be paid to the specifications in the operating instructions..

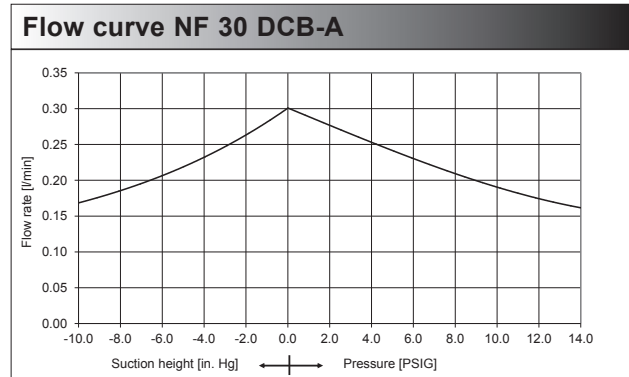
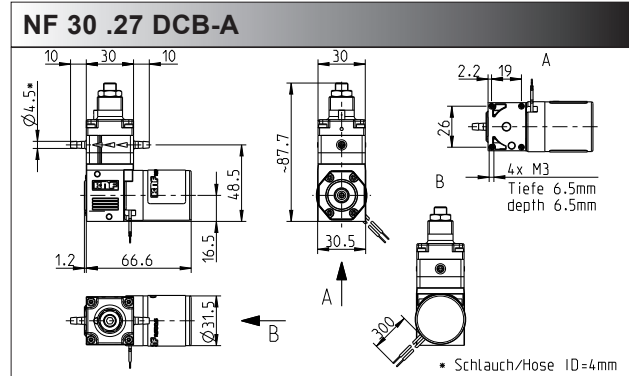
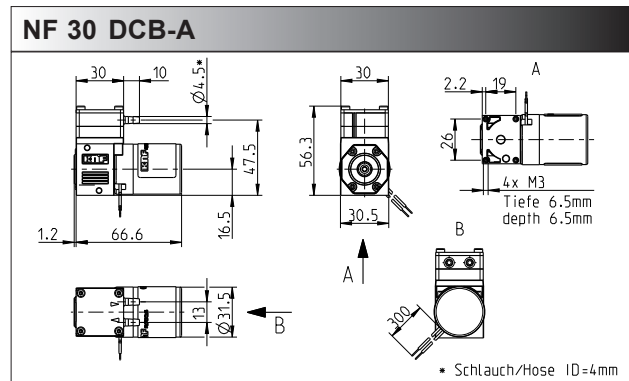

NFB 30-DCB



Performance

Basic model	Flow rate at atmos. pressure (l/min)	Max. suction head (inHg)	Max. pressurhead (PSIG)
NFB 30 DCB	2 x 0.3	17.7 ¹⁾	14.5

¹⁾ For models with PTFE diaphragm: max. 14.7 inHg

Motor selection	DCB
Voltage (V)	12 / 24
Power rating (W)	10.5 / 10.6
I max. load (A)	0.87 / 0.44
I max. (A)	0.93 / 0.46
EMC guideline ²⁾	EN 55022 EN 55011
Weight (g)	315
Motor protection factor	IP 30

²⁾ In order to comply with the above standards attention must be paid to the specifications in the operating instructions.

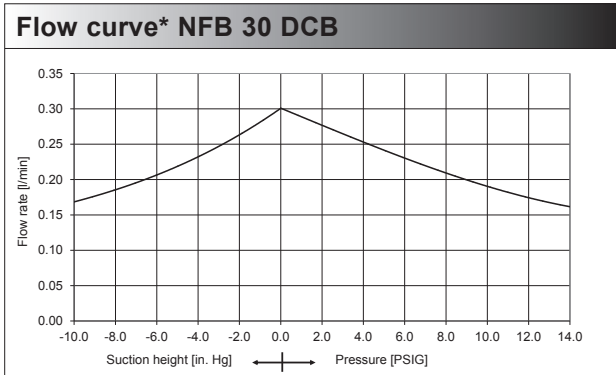
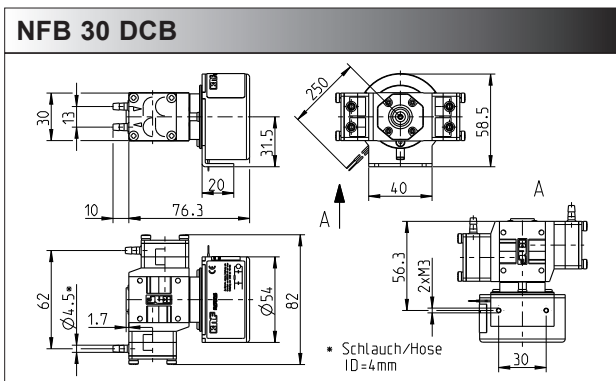

Flow rate per pump head - the two heads are in phase

KNF NEUBERGER, INC.

Two Black Forest Road
Trenton, New Jersey 08691-1810
Phone: 609-890-8600 FAX: 609-890-8323
Web: <http://www.knf.com>

Accessories

Diaphragm pressure control valve

The pressure control valve can be used for a more accurate control of flow against a fluctuating back pressure, metering into a vacuum and from a pressurised system. Used correct it can save pumps, plumbings and other fittings from damage. Example FDV 30 KPZ, for more information see data sheet FDV

Pulsation damper

This very versatile pulsation damper reduces the vibration in hoses and pipes and it helps to remove pulsation which is preventing the system from functioning correctly. It also protects instrumentation connected after the pump. Suggestion FPD 06 KPZ-1, for more details see data sheet FPD.

Further accessories

- Hoses
- Hose connections
- Shock mounts
- Suppression device for DCB motor (ID-Nr. 068713)

Options



NSF National Sanitary Foundation

NSF is market leader in the development and controlling of standards relevant for equipment used for handling foodstuffs. By using different toxicological tests our products will be certified according to the standard NSF/ANSI 169. This certification will confirm that all of the pumps with the code .51 are certified for the use with foods/consumables. In addition to this it also means that the pumps are constructed with wetted parts which come with a FDA* declaration of conformity. A yearly audit from NSF will be carried out to ensure that these standards are being maintained. A list of the various products are available on request.

* FDA = Food and Drug Administration

Further options

- Connections: M5, UNF 1/4"-28, 4/6 mm hose connector
- Head material: Stainless steel, PPS, PA MXD 6 etc.
- Suitable for hot fluids up to 135°C
- Suitable for pressure over 1.0 bar
- Portable version specially suitable for laboratory applications. IP21 housing is equipped with an integral mains transformer and an ON/OFF switch
- High protection IP65 version for applications under bad conditions (moisture, dust), for NF 30-DC
- Motors with special voltages and frequencies
- The incorporation of customers special requirements, for example special electrical connections (Molex, AMP, etc.)