

SWING PISTON COMPRESSORS AND VACUUM PUMPS FOR AIR

Section 300.30



NPK 018 ... DC



NPK 018 ... AC

Concept

The Swing Piston Pumps from KNF are based on a simple principal: As it rises and falls the piston tilts first to one side, then the other. The compression forces act along the axis of the connecting rod, so that there is no component of force acting against the cylinder wall to cause wear. Thanks to the sealing lip on the piston seal the swing piston pump runs dry, and 100% oil-free. They will evacuate, transfer and compress air without contamination.

For customers with unusual requirements the KNF Project Team produces specially tailored solutions. Use our experience to your advantage and talk to our applications engineers.

Features

- Uncontaminated flow**
No contamination of the air due to oil-free operation
- Maintenance-free**
- High level of flow-rate**
- Excellent price performance ratio**
- Very quiet and little vibration**
- Ready for installation**
- Can operate in any installed position**

Areas of use

The Swing Piston Pumps offer a high level of performance despite their small size, as well as an excellent price performance ratio. They are used especially in the fields of medicine, environmental and production technology. These pumps are used for transferring, compressing and evacuation air, taking samples, evacuating vessels and compressing air in process systems and vessels.

PERFORMANCE DATA

Type	Delivery (l/min)	Vacuum (mbar absolute)	atm. Press.	Pressure (bar g)	Weight (kg)
NPK 018 Vacuum AC	18	120			1.9
NPK 018 Pressure AC	15			1.5	1.9
NPK 018 Vacuum DC	18	120			1.9
NPK 018 Pressure DC	18			1.5	1.9

NPK 018...DC

PERFORMANCE DATA

Type Order code ²⁾	Delivery at atm. pressure (l/min) ¹⁾	Max. operating pressure (bar g)	Ultimate vacuum (mbar abs.)
NPK 018 Vacuum DC	18	-	120
NPK 018 Pressure DC	18	1.5	-

¹⁾ Litre at STP

²⁾ See also „MODEL CODES FOR EASY ORDERING“

MOTOR DATA

DC Motors to available	12 V	24 V
------------------------	-------------	-------------

NPK 018...AC

PERFORMANCE DATA

Type Order code ²⁾	Delivery at atm. pressure (l/min) ¹⁾	Max. operating pressure (bar)	Ultimate vacuum (mbar abs.)
NPK 018 Vacuum AC	18	-	120
NPK 018 Pressure AC	15	1.5	-

MOTOR DATA

Protection class	IP 00	IP00	
Voltage/Frequencies (V/Hz)	~230/50	115/60	
Power P ₁ (W)	130	130	
Operating current (A)	1.3	2.5	

Motors with other voltages, frequencies and protection classes on request.

Dimensions mm (All dimensional tolerances conform to DIN ISO 2768-1, Tolerance Class V)

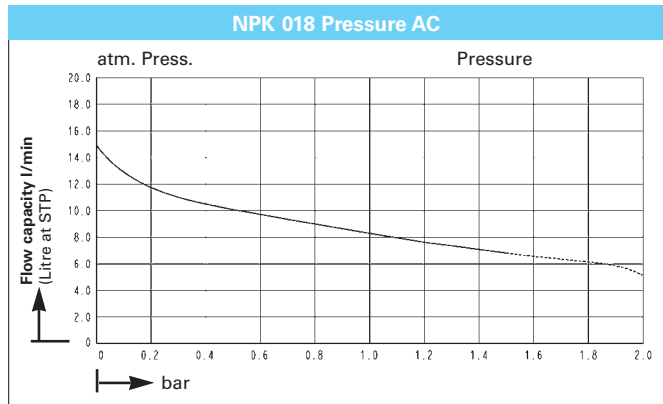
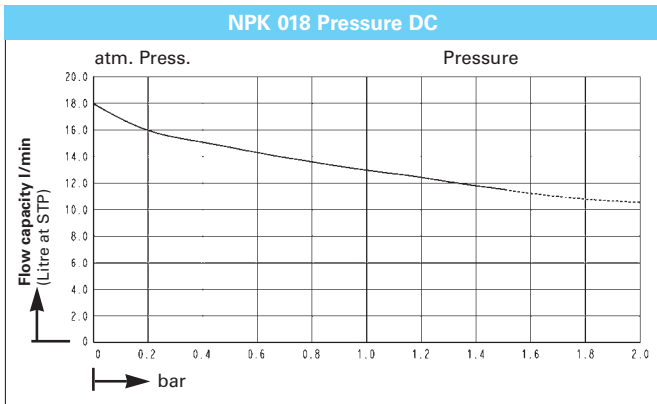
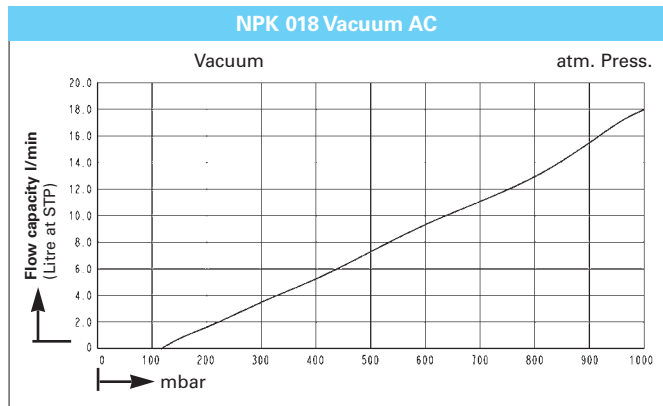
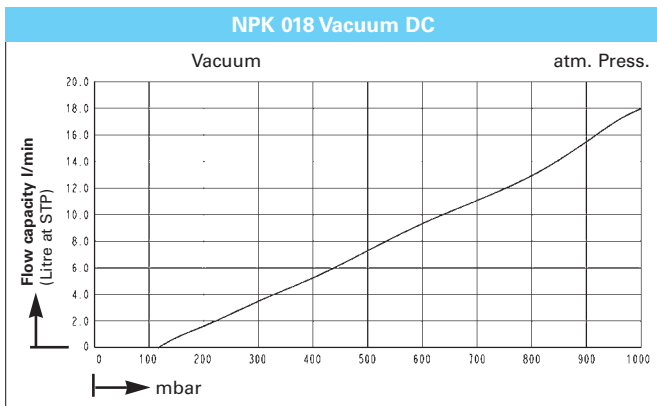
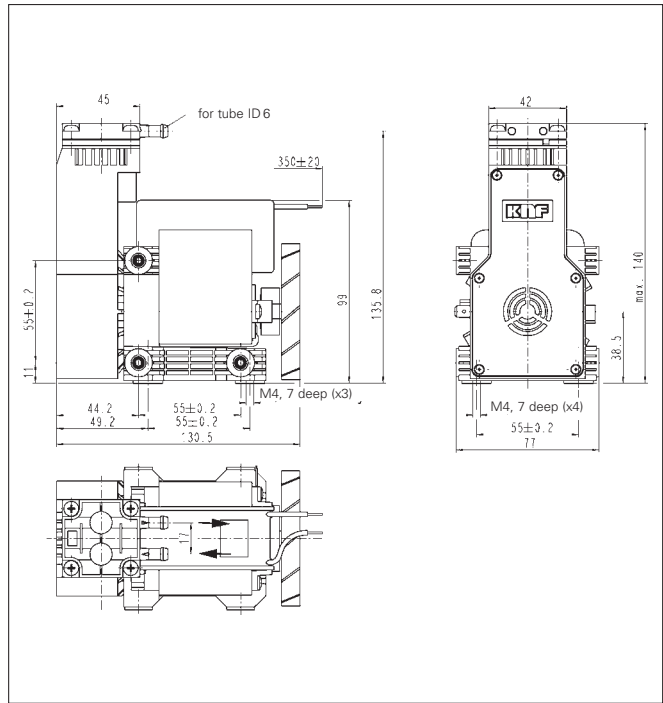
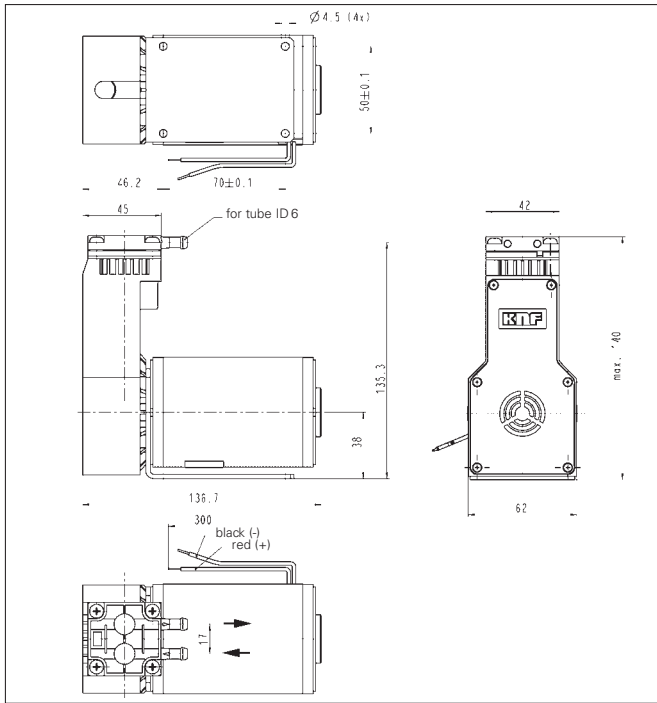

----- for short periods only