

SWING PISTON VACUUM PUMPS AND COMPRESSORS FOR AIR

SECTION 300.20

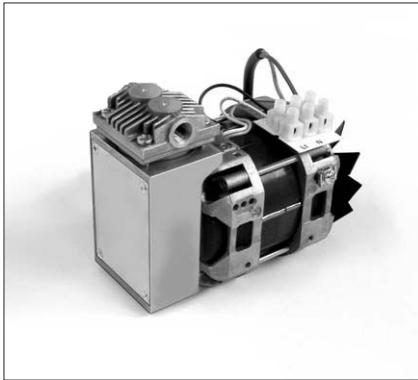

NPK 09 AC



NPK 09 DC



NPK 09.1.2 AC

Concept

The Swing Piston Pumps from KNF are based on a simple principal: As it rises and falls the piston tilts first to one side, then the other. The compression forces act along the axis of the connecting rod, so that there is no component of force acting against the cylinder wall to cause wear. Thanks to the sealing lip on the piston seal the swing piston pump runs dry, and 100% oil-free. They will evacuate, transfer and compress air without contamination.

For customers with unusual requirements the KNF Project Team produces specially tailored solutions. Use our experience to your advantage and talk to our applications engineers.

Features

No contamination of the air due to oil-free operation

Maintenance-free

High level of flow-rate

Excellent ultimate vacuum

Very quiet and little vibration

Ready for installation

Can operate in any installed position

Areas of use

The Swing Piston Pumps offer a high level of performance despite their small size, as well as an excellent price performance ratio. They are used especially in the fields of medicine, environmental and production technology.

These pumps are used for transferring, compressing and evacuation air, taking samples, evacuating vessels and compressing air in process systems and vessels.

PERFORMANCE DATA

Type	Delivery (l/min)	Vacuum (mbar absolute)	atm. Press.	Pressure (bar g)	Weight (kg)
NPK 09 AC	12	100		7	1.8
NPK 09 DC	15	100		7	1.6
NPK 09 .1.2 AC	24	100		7	2.4

NPK 09 AC

NPK 09 DC

PERFORMANCE DATA

Type and Order No. ²⁾	Delivery at atm. pressure (l/min) ¹⁾	Max. operating pressure (bar g) ³⁾	Ultimate vacuum (mbar abs.)
NPK 09 AC	12	7	100

¹⁾ Litre at STP ³⁾ continuous running

MOTOR DATA ⁴⁾

Protection class	IP 00		
Voltage/Frequencies (V/Hz)	230/50		
Power P ₁ (W)	100		
Operating current (A)	0.6		

²⁾ See also „MODEL CODES FOR EASY ORDERING“

⁴⁾ Motors with other voltages, frequencies and protection classes on request..

PERFORMANCE DATA

Type and Order No. ²⁾	Delivery at atm. pressure (l/min) ¹⁾	Max. operating pressure (bar g)	Ultimate vacuum (mbar abs.)
NPK 09 DC	15	7	100

¹⁾ Litre at STP

MOTOR DATA ⁴⁾

DC Motor	12 V	24 V	
Operating current (A)	5.2	2.6	

Dimensions mm (All dimensional tolerances conform to DIN ISO 2768-1, Tolerance Class V)

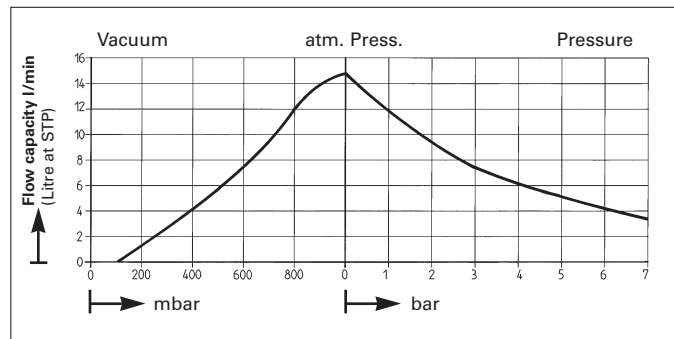
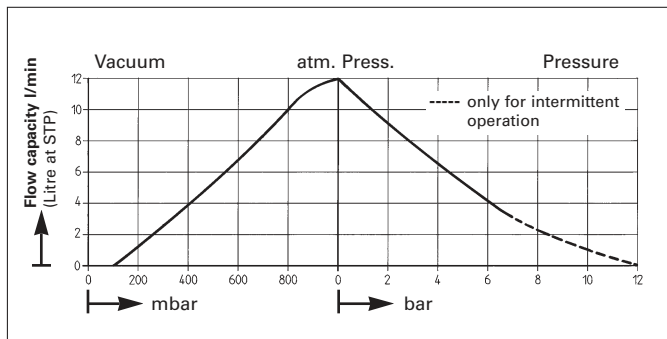
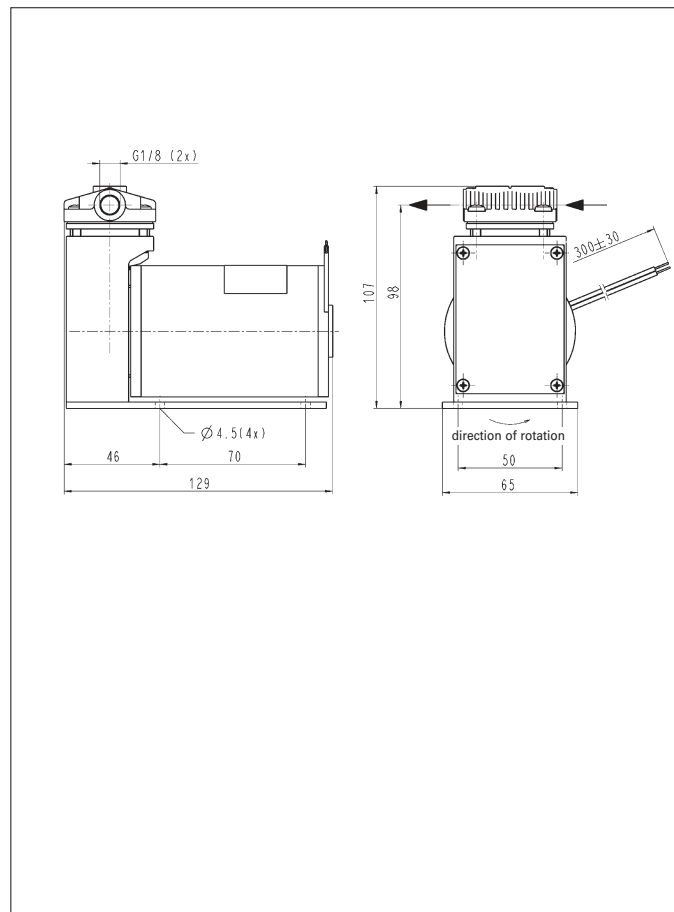
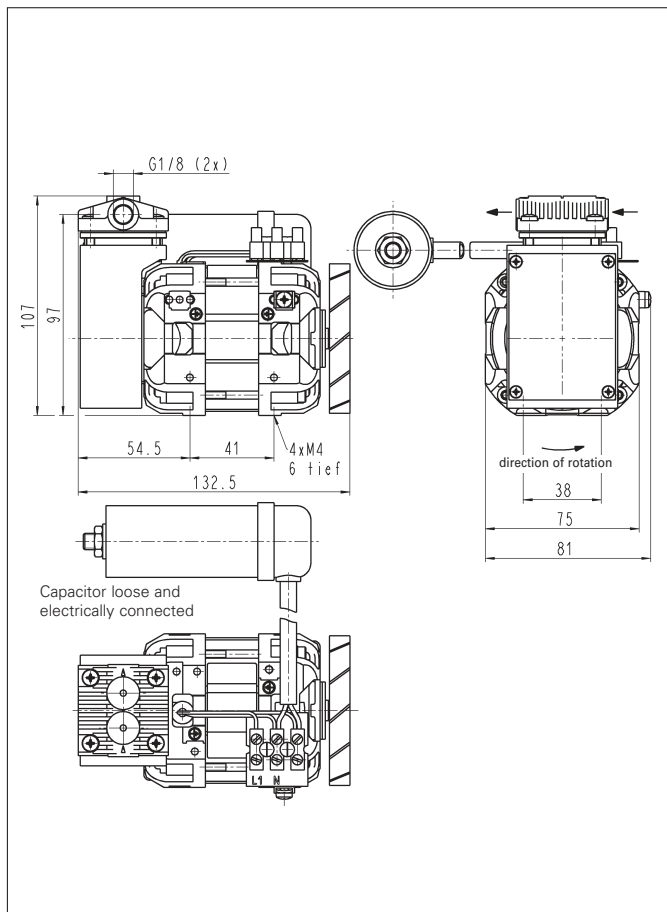

NPK 09.1/.2/.1.2 AC

PERFORMANCE DATA

Type and Order No. ²⁾	Delivery at atm. pressure (l/min) ¹⁾	Max. operating pressure (bar g)	Ultimate vacuum (mbar abs.)
NPK 09.1 AC	24		100
NPK 09.2 AC	24	7	
NPK 09.1.2 AC	24	7	100

¹⁾ Litre at STP

MOTOR DATA ⁴⁾

Protection class	IP 00		
Voltage/Frequencies (V/Hz)	230/50		
Power P ₁ (W)	180		
Operating current (A)	0.8		

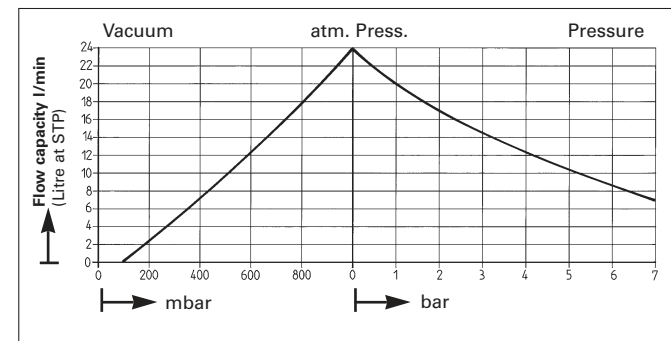
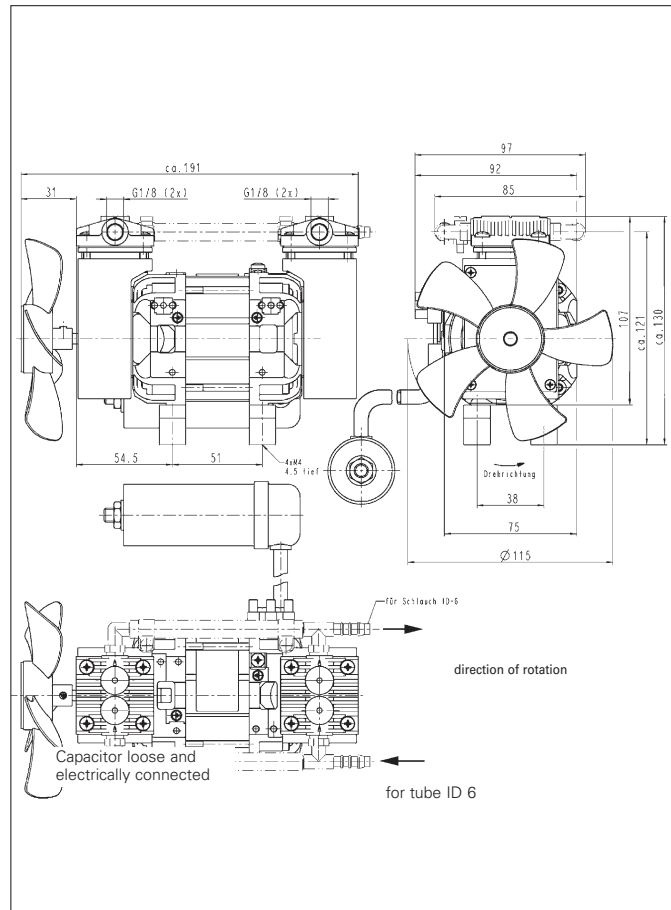

Connections

Description	Order No.	Detail
NPK 09.1, NPK 09.1.2 (suction side)	026178	Polyamide/rubber
NPK 09.2, NPK 09.1.2 (press. side)	026179	Polyamide/rubber

Head connections

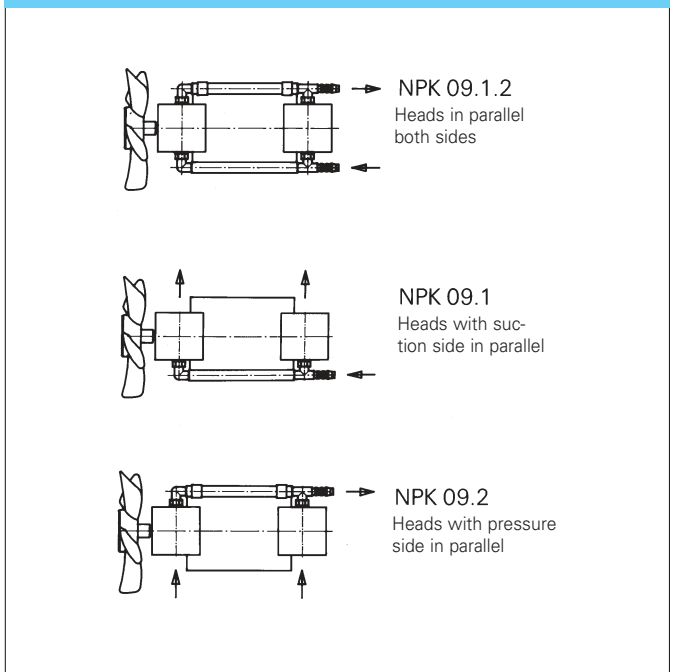

KNF NEUBERGER, INC.

Two Black Forest Road
Trenton, New Jersey 08691-1810
Phone: 609-890-8600 · Fax: 609-890-8323
Web: <http://www.knf.com>