

VACUUM PUMP SYSTEMS

LABOBASE® SBC 840.40 AND SBC 860.40

DATA SHEET E 294



Technical features

- For up to ten users
- Fully-automated vacuum generation system comprising chemically resistant diaphragm vacuum pump, base plate, high-performance condenser, separator, vacuum control device, valves and control unit
- Vacuum supply point with regulated tapping
- Simple connection to the line power (power plug) and to the pneumatic system
- Environmentally friendly
- Chemically resistant

Technical data

	SBC 840.40	SBC 860.40
Flow rate [m ³ /h] at atm. pressure	2.04	3.6
Flow rate [l/min] at atm. pressure	34	60
Ultimate vacuum [mbar abs.]	10	4
Operating pressure [bar]	1	1
Voltage [V]	230	230
Frequencies [Hz]	50	50
Motor protection	IP 44	IP 54
Power P ₁ [W]	245	220
Operating current [A]	1.5	1.6
With overcurrent protection and main fuse		

MATERIALS

Pump head	PTFE
Diaphragm	PTFE-coated
Valves	FFPM

OTHER DATA

	SBC 840.40	SBC 860.40
Total weight [kg]	22.9	25.3
Hose connections	ID 10	ID 10
Dimensions W x H x D [mm]	450 x 515 x 322	314 x 552 x 437
Permissible media and ambient temperature [°C]	+5 ... +40	+5 ... +40

ACCESSORIES

	ID
Coolant valve – G 1/2, ID 8	045075
Gas washing bottle 0.5 l	045886
Non-return valve – unregulated, for fume hoods (PE-HD)	118366 118364
Vacuum supply point – unregulated, for installation in laboratory equipment (PPS)	118362
Mobile controller unit for regulated vacuum supply (chemically-resistant)	048459

Dimensions

SBC 840.40

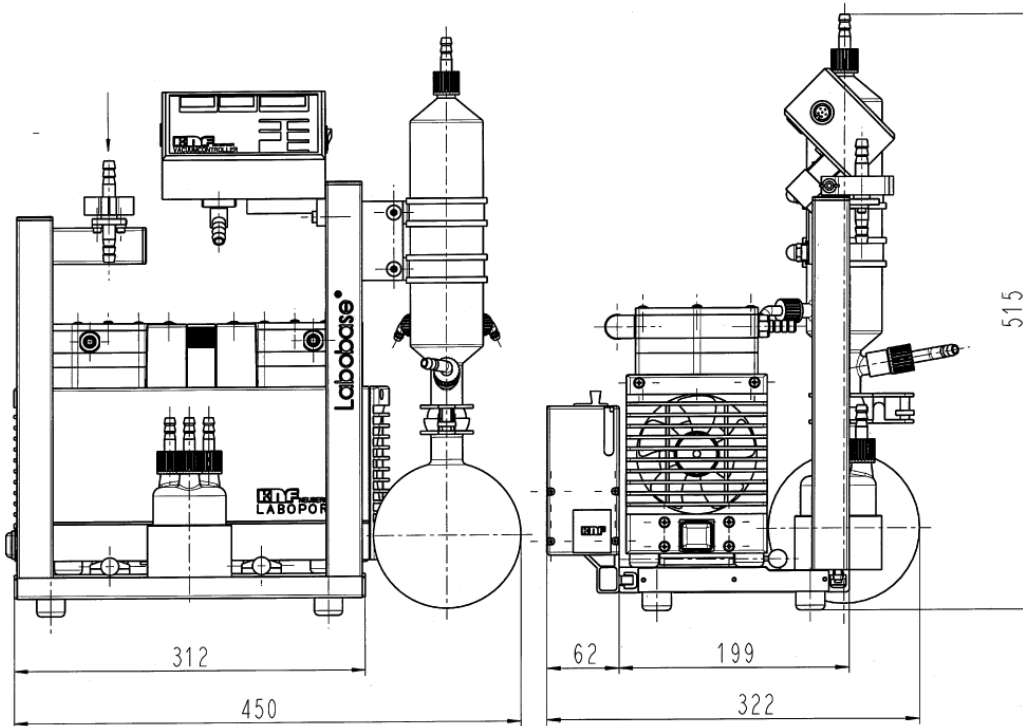

SBC 860.40

